

# 8C

## 8FT CORNER SUMMERHOUSE INSTRUCTIONS

# SHEPAST

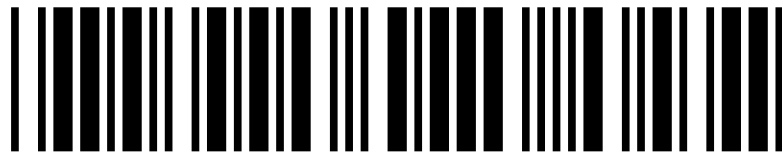

AS442



# Introduction

## Warranty -

Your Shedfast shed is guaranteed for two years against faulty manufacture as long as you treat it within two weeks of assembly with our recommended treatment. The guarantee would supply replacement planks or parts for any defective items (ie rarely a full panel) for self installation. Wind damage, non-domestic use, accidental or deliberate damage and Labour are all excluded from the guarantee.

## Care and Maintenance-

Your Shedfast shed is made from good quality Scandinavian timber and should give you years of reliable use. However it is important to be aware of the natural properties of wood and accept these changes as they crop up on your shed. This kind of timber is affected by humidity which expands the timber as it gets wetter and shrinks it as it dries out. For this reason it is highly beneficial to treat your shed immediately when it is assembled with a good quality wood treatment. We offer the Shedfast original larch colour in a 2.5l can and you should use this if you want to keep a similar colour to the original. Alternatively, if you want to paint your new building in a coloured finish, then we offer the Protek Royal exterior which is a superb quality coating.

Although your shed comes with a factory applied premium protector treatment, the benefits of hand painting the shed immediately with one of our recommended treatments are so profound that we will only activate the 2 year warranty if your shed is coated with one of our recommended treatments within 2 weeks of assembly.

Please be aware that timber is a natural product and can split, warp, cup, expand and contract, leech sap, shed knots, shake and twist. These matters can be mitigated by applying a treatment immediately when you get your shed and by filling shakes, splits and knot holes as they crop up as a part of your ongoing maintenance. Check your shed annually and fill any defects that have developed.

## Safety information-

- Glass and timber can potentially cause injury. Please ensure you wear protective goggles, gloves, headgear and suitable footwear when assembling the building.
- Please remember that glass is fragile and should be handled with extreme care. Always clear up and dispose of any breakages immediately.
- Do not assemble the shed in high winds.
- For safety reasons and ease of assembly when self-assembling, we recommend that this shed is assembled by two people.
- Please clear all lying snow from the shed roof as it can cause the roof to buckle or collapse.
- Please do not stand directly or put your whole body weight on the roof.

## Site preparation-

- When selecting a site for your shed, it is vital that you choose as flat and level an area as possible.
- A concrete or slabbed base will provide the most solid foundation for your shed. It is important the base is level.
- Avoid placing your shed under trees or in other vulnerable locations if possible.
- To minimise the risk of wind damage, try to select as sheltered a site as possible, e.g. beside a hedgerow or garden fence.

## Tools required-

- Drill
- Spirit Level
- Knife
- Ladders
- Hammer
- Screwdriver
- Tape Measure

## Pre Assembly

- Before you start, check you have all the correct components required for the build. See the tables on the back pages to check this.
- Remove any of the transit blocks, but be careful when laying the panels down to not snap any of the over-hanging cladding.

## Doors-

Please ensure that your door is securely fastened in windy conditions to prevent damage to the hinges or door posts.

## Felt-

Your shedfast building comes with a good quality polyester backed felt which is harder to rip than regular shed felt. Keep an eye on your felt as a part of your ongoing maintenance and repair or replace it promptly if it deteriorates (for example after a storm) before water has chance to get in and damage the shed.



## Floor Assembly

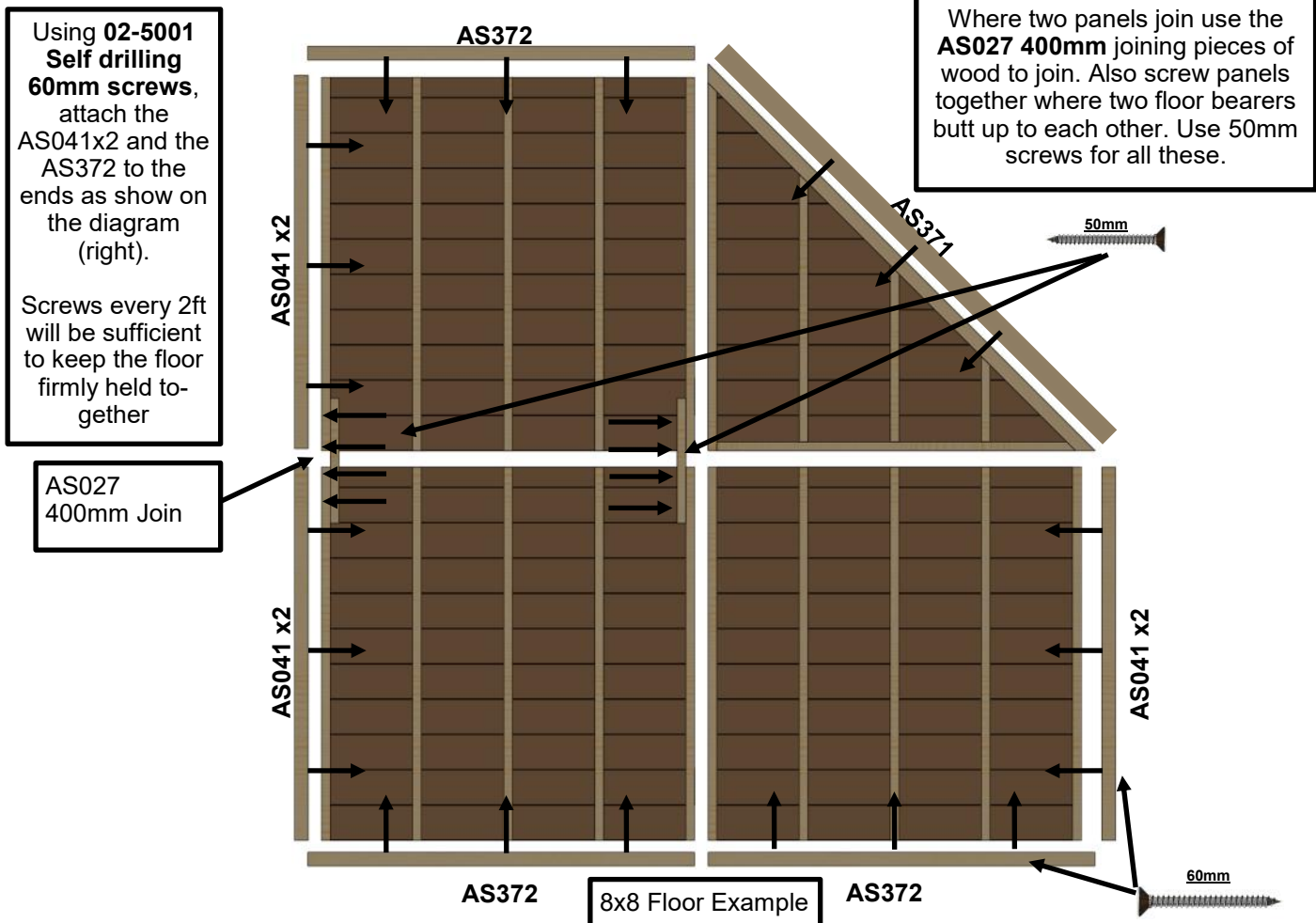

## Laying the floor onto the base

Once you have assembled the floor you need to now lay this onto the base. Ensure the base is flat and level by using a spirit level. Then lay the assembled floor onto the base, once again checking that everything is flat and level.

A flat and level base is vital because if it is not level then you will experience problems such as the door not opening or closing properly, the roof not fitting properly and you may get gaps appearing. Use the spirit level across the width and length of the floor.

**NOTE:** Flipping the floor over and laying it onto the base should be done very carefully to avoid damage to the floor.



**TIP:**  
Take time to make sure your original base + your wooden floor is level. The door will be affected if not level. If your concrete or slabs are uneven, you could consider ordering the optional Shedfast wooden base system

## Sides Assembly

### Removing the transit blocks

Before you start putting the sides onto the floor, you need to remove the transit blocks. They are nailed on to protect the overlapping cladding from snapping while in transit. Remove these blocks carefully using a hammer.



You will receive **4 x ASA1006** panels in total. To prepare the side panels to meet at a corner, you need to attach your **AS364** 44x44 1856mm to **ASA1006** using **50mm wood screws**. Attach the **AS364** to the **left** side of 2 of the panels and to the **right** of 1 of the panels. The 4th panel can be left as it is. See below

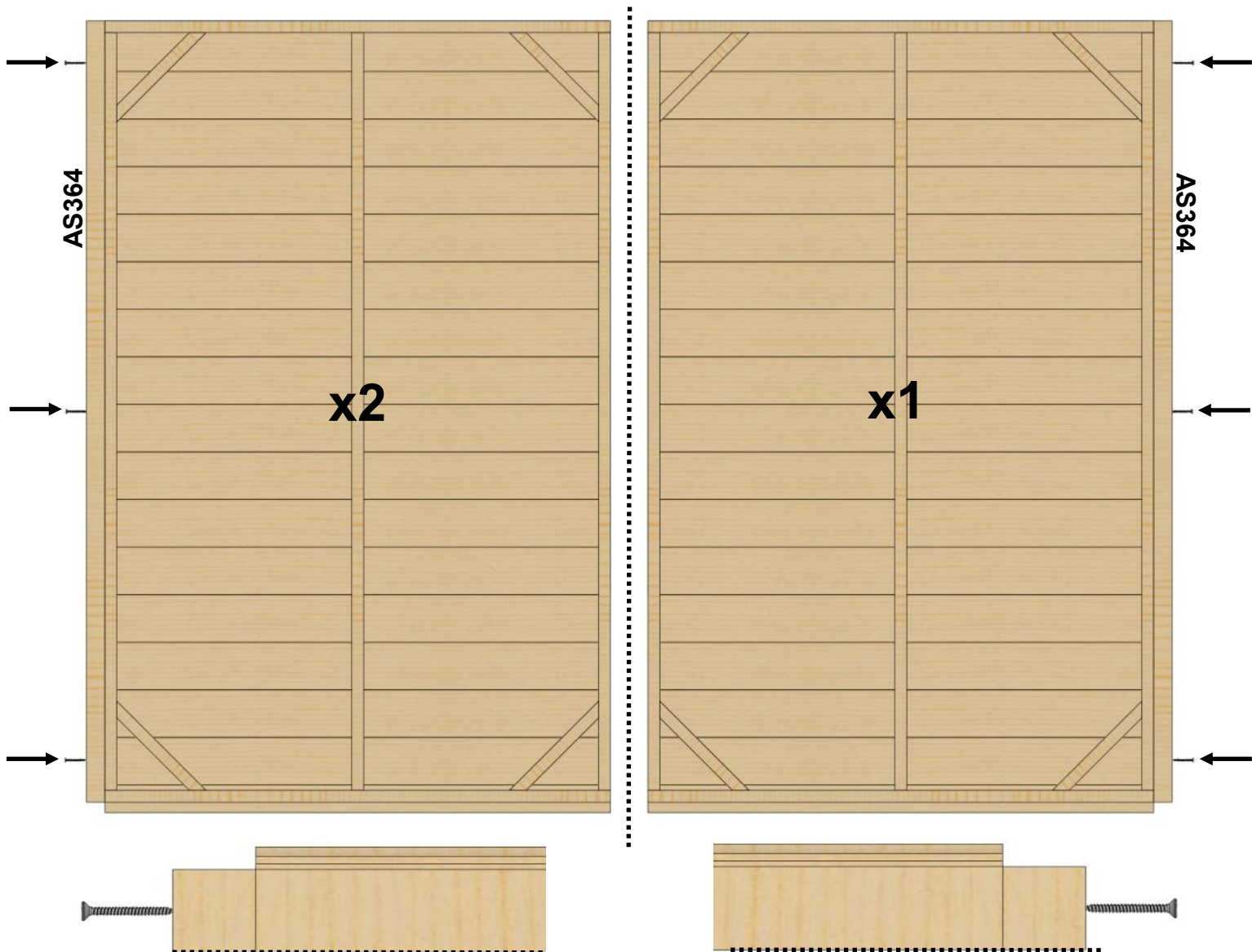



Pilot Hole size:

## Sides Assembly

You can now begin to attach the ASA1006 sides together. When attaching the sides together, use three **50mm wood screws** per vertical and ensure you make pilot holes with a 4mm drill bit.

=4mm

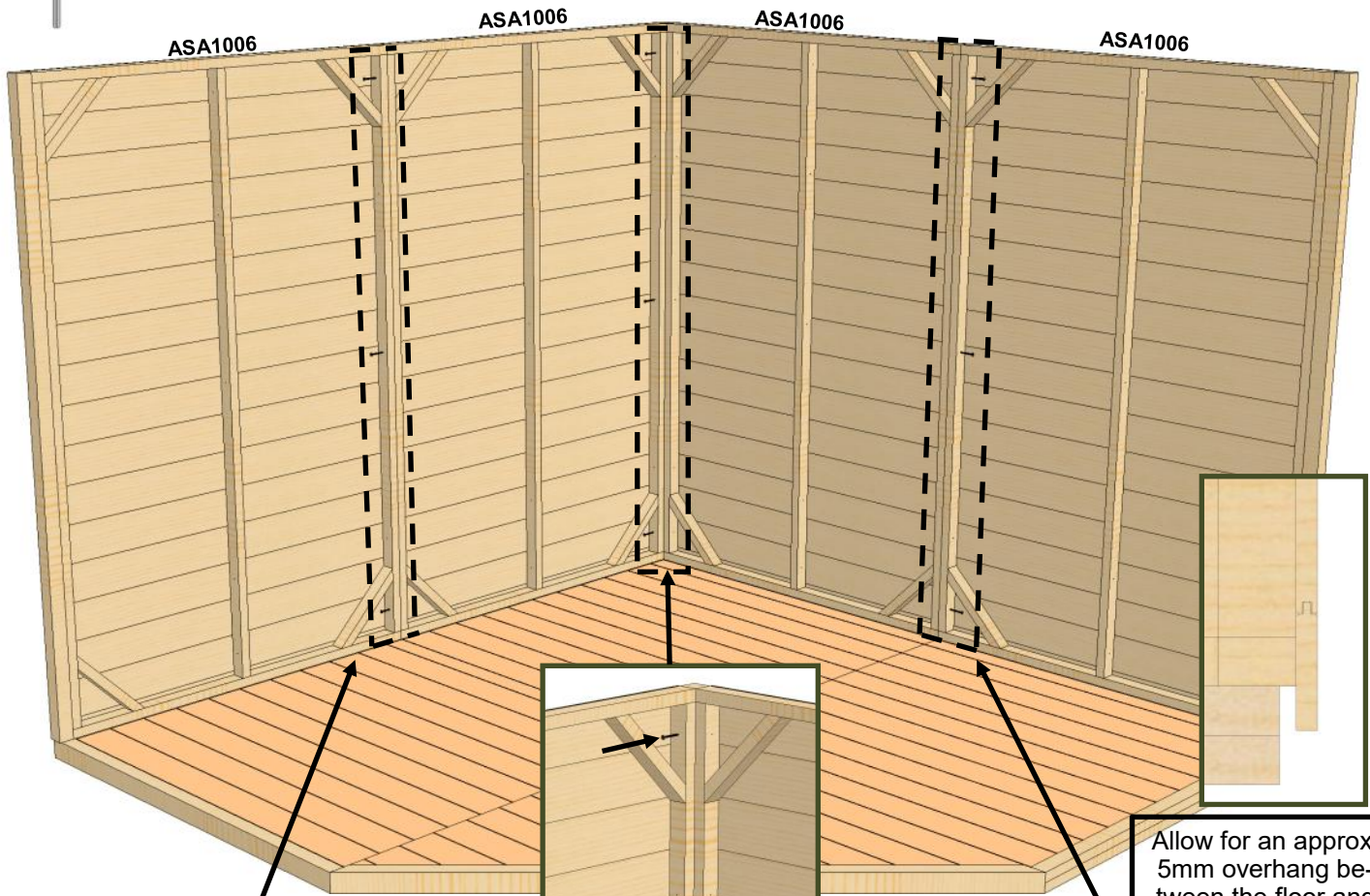

Allow for an approx. 5mm overhang between the floor and the side panel.

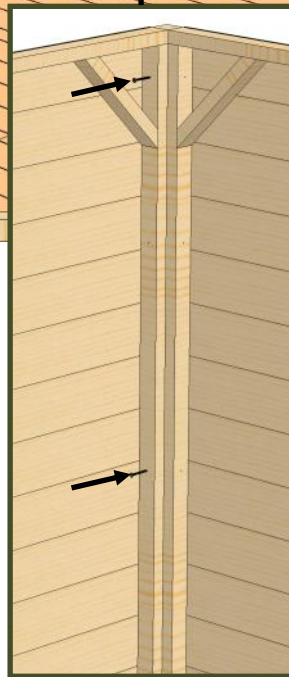
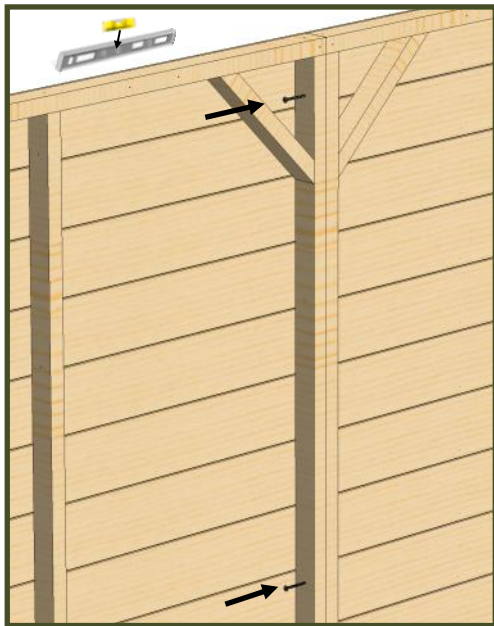

AERIAL VIEW

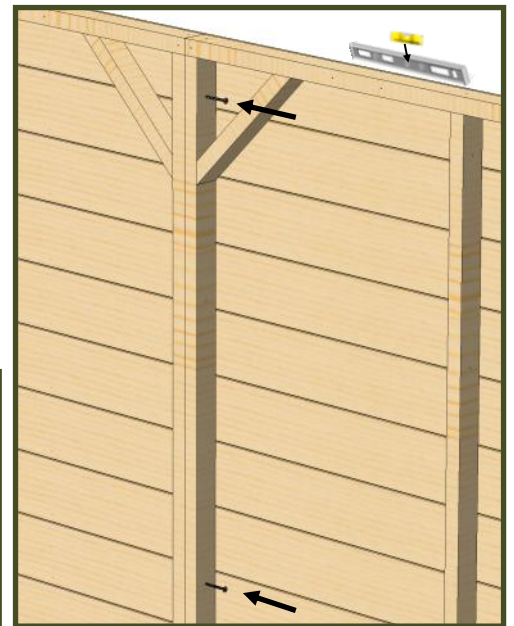
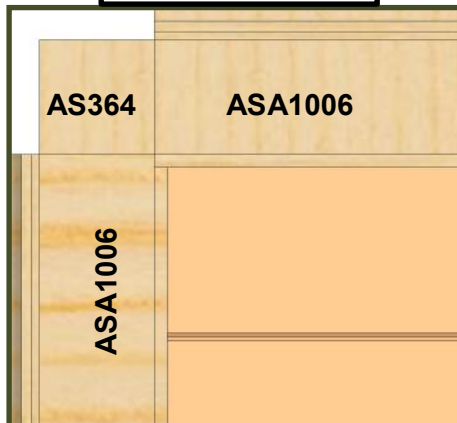

# Sides Assembly

Now it is time to attach the windows and door panels. Look below to see which screws to use. The **60mm screws** will be needed for joining the panels with the wedge inbetween.

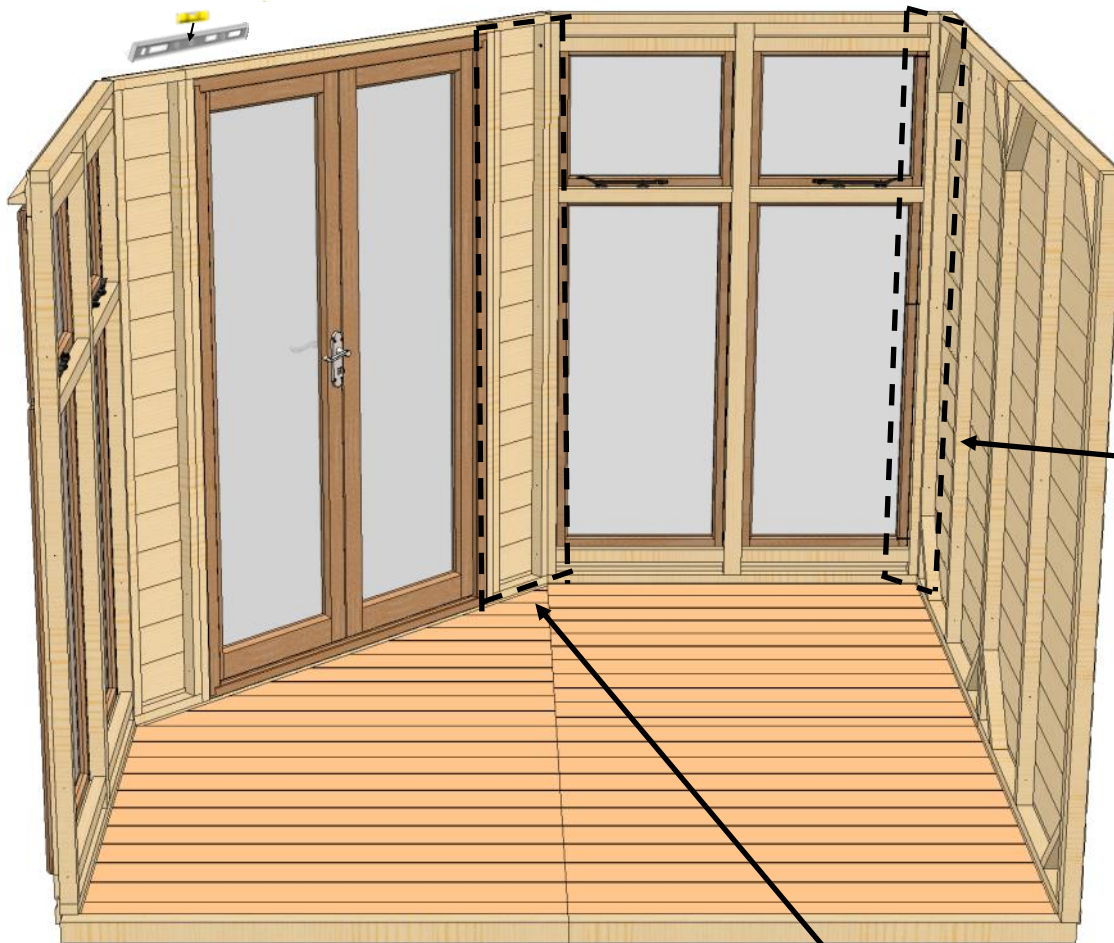

Repeat these steps on the other side of the door until all of the side panels are attached and secure.

Do not screw down to the floor just yet, this can be done at the end.

## Door Handle

Your door will arrive already installed in the frame with the lock and lock plate attached. All you need to do is attach the door handle to install this to the building. Start by sliding the spindle through the top hole in the door then locate one of the door handles on this and fix with the screws provided. Repeat this on the other side of the door

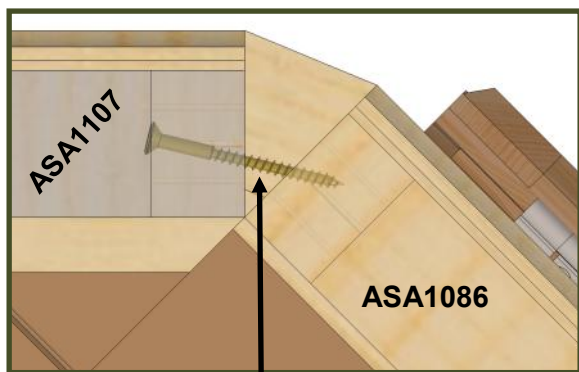

**60mm Screws**

See how the **60mm screw** goes through these **ASA1107** and into the **ASA1086**

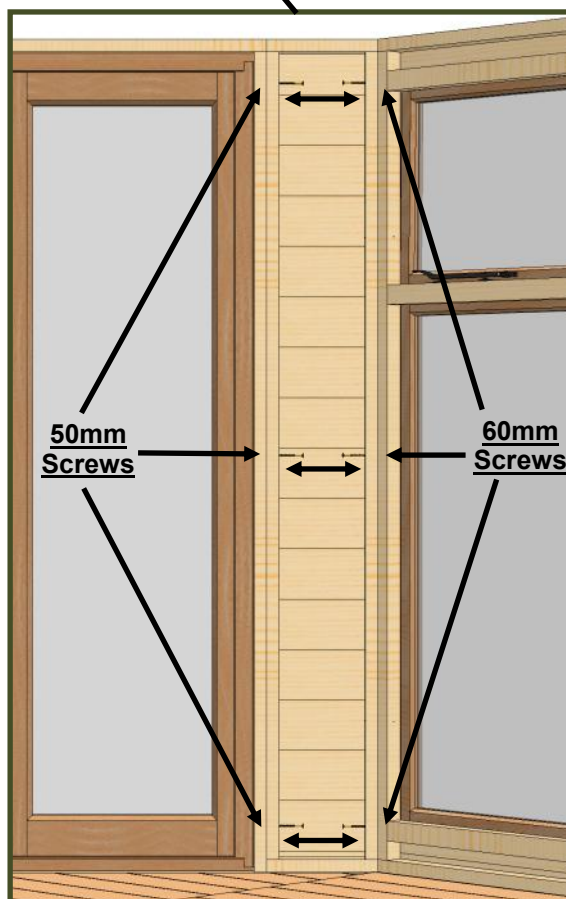

## Top Panels

Now it is time to attach your **ASA1108 Above door panel**. You can then attach this down to the **ASA1088** and **ASA1107** using **50mm screws**.

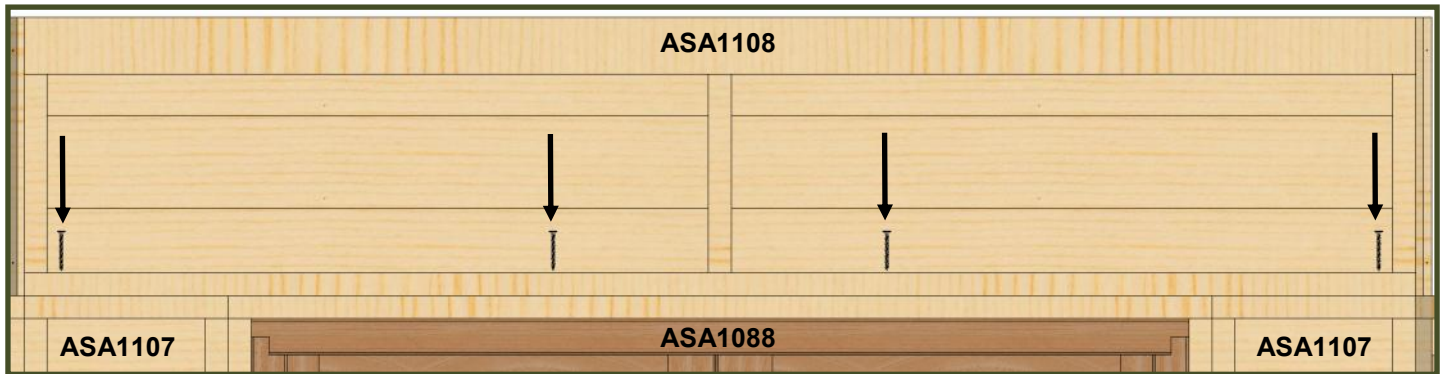

You can then attach the **ASA1109/ASA1110** to above the **ASA1086** using **50mm screws**. You can then screw into the previously installed **ASA1108** using **60mm screws**. See images below

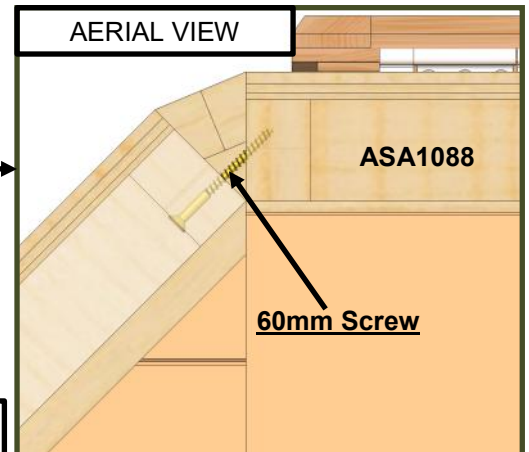
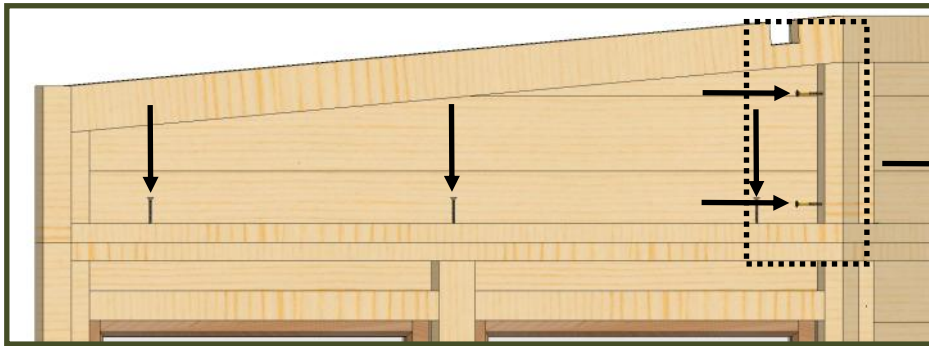

Next, you can attach your **ASA1111/ 1112/ 1113/ 1114** Panels using **50mm screws**. See the arrows below for where to drill from.

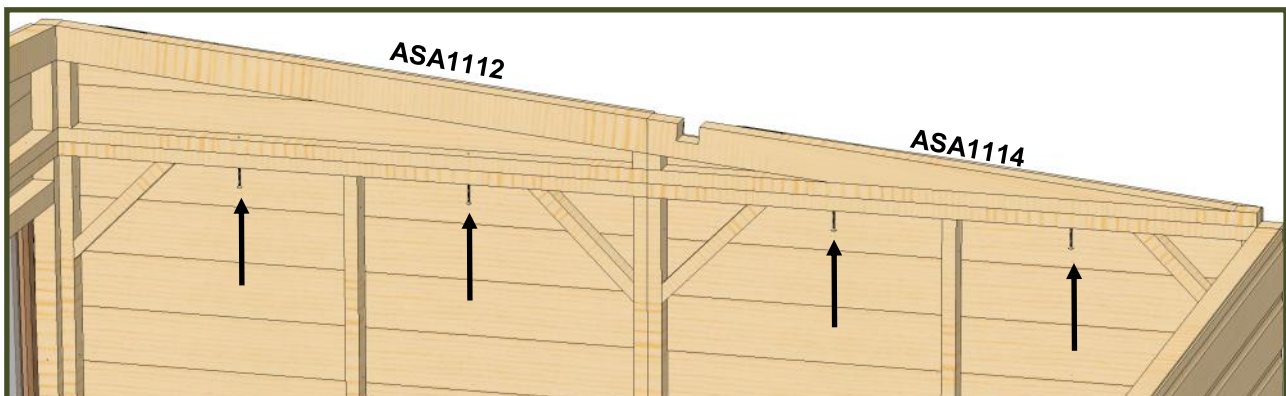
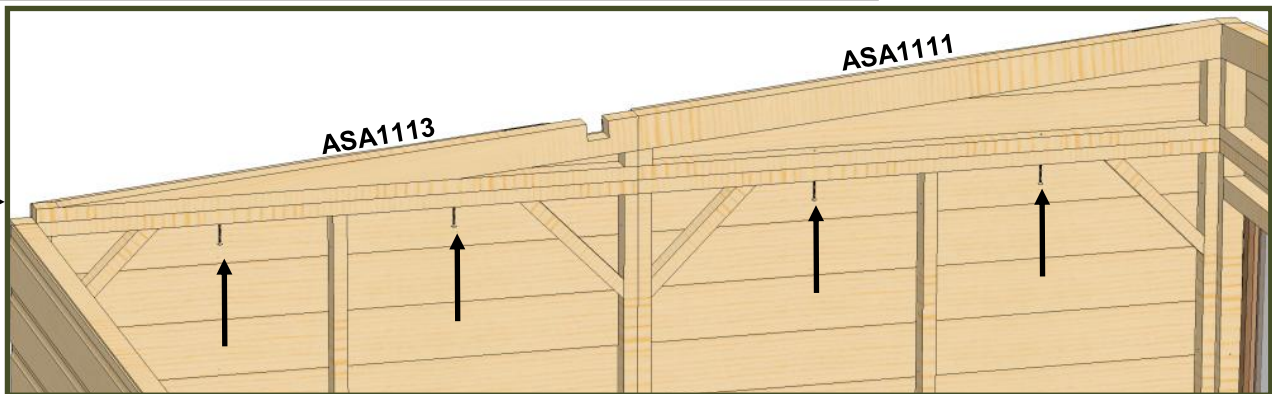

# Roof Supports

You need to assemble your roof support beams. You will receive 2 different lengths which will be held together with 2 screws from the top and then the bracket on the underside. See the below.

You will have 2 sets of roof supports that you need to assemble.

## Step 1

Bring your two parts together as seen below

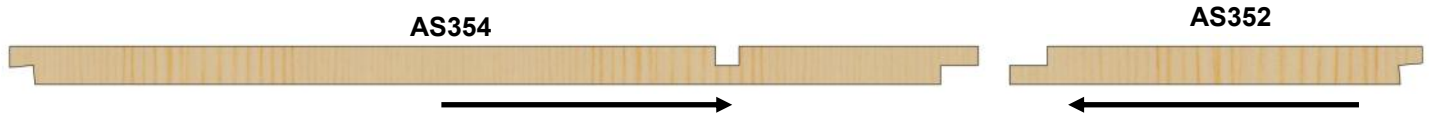

## Step 2

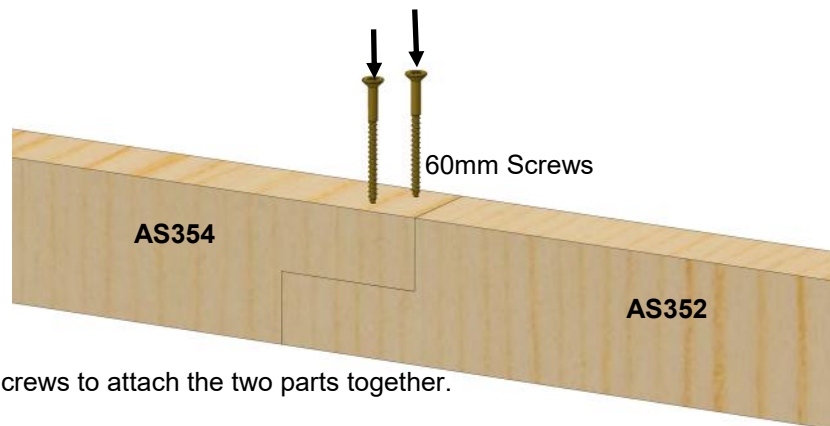

Use x2 60mm screws to attach the two parts together.

## Step 3

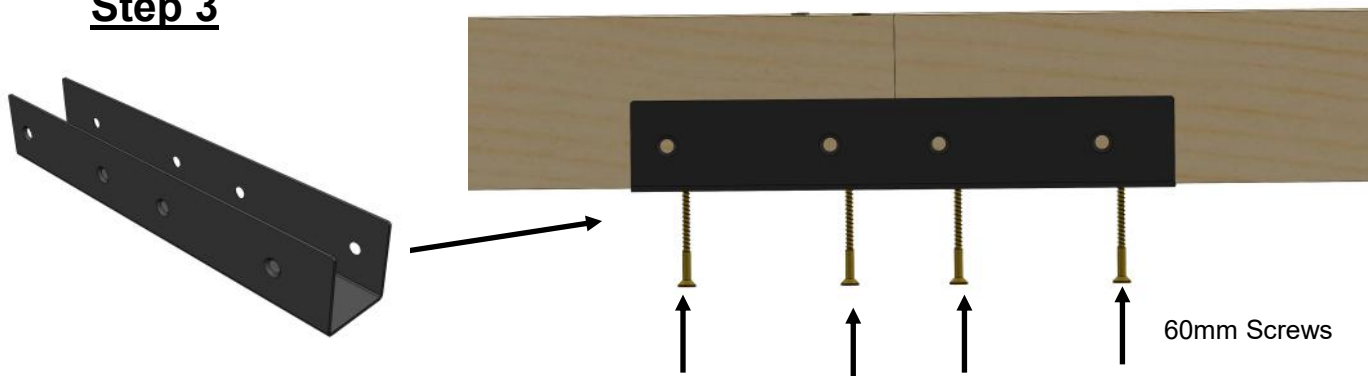

Equally space the bracket over the join and secure down with 60mm screws.

## Step 4

Use 4 x 35mm screws on each side to secure the bracket into place. Be sure to do this on both sides

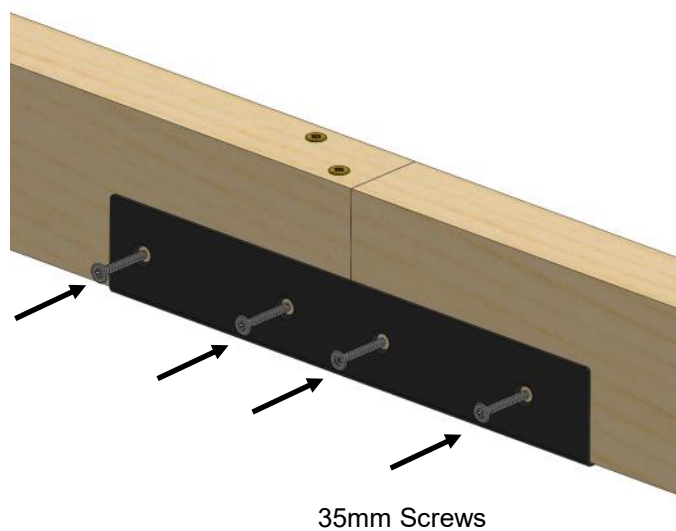

### Step 1

Bring your two parts together as seen below

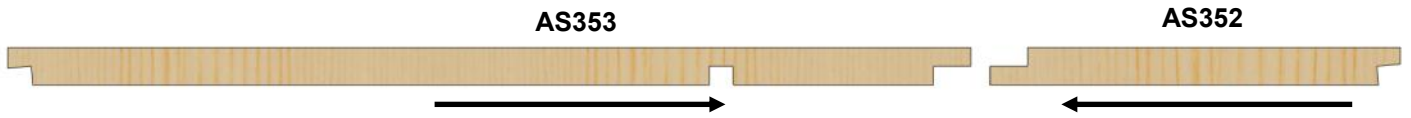

### Step 2

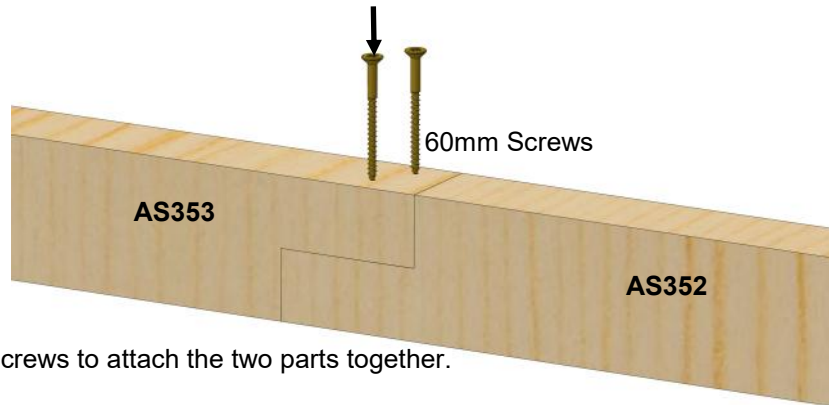

Use x2 60mm screws to attach the two parts together.

### Step 3

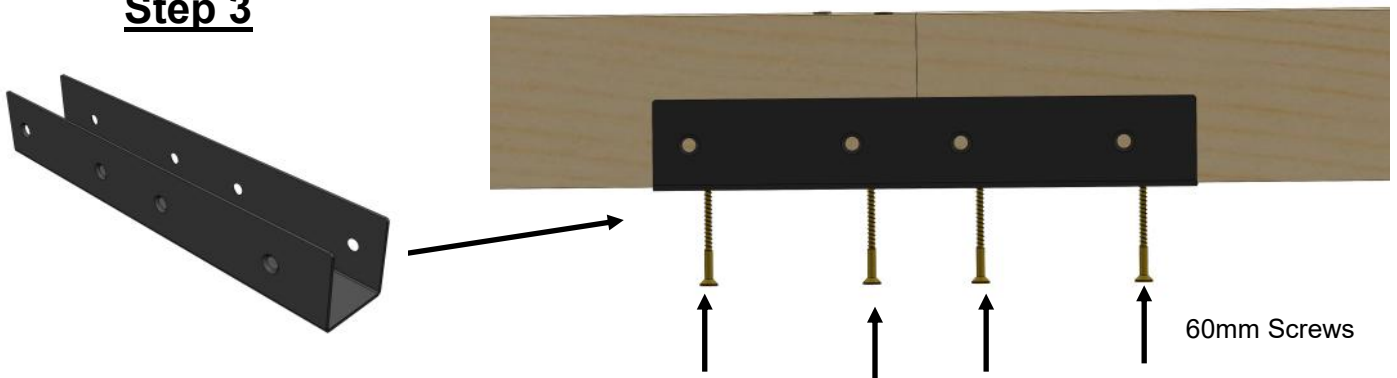

Equally space the bracket over the joint and secure down with 60mm screws.

### Step 4

Use 4 x 35mm screws on each side to secure the bracket into place. Be sure to do this on both sides

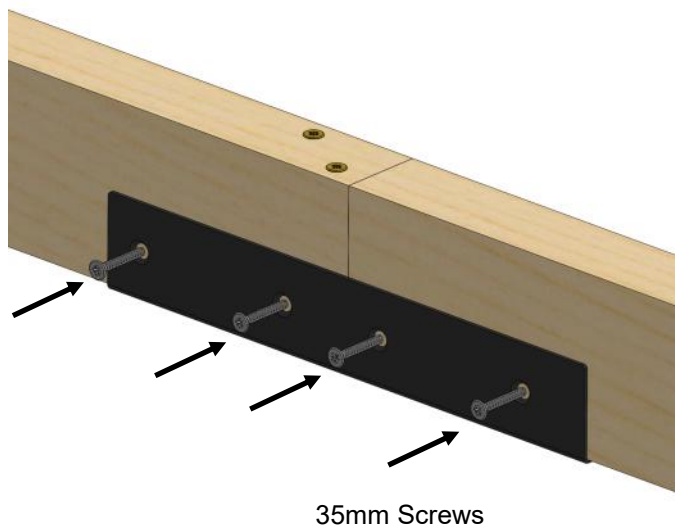

# Roof Supports

Now it is time to put the roof supports into position. The first one that goes in should have the cut out facing the sky, this will allow for the other roof support to slot on top of that. See below

The half lap of the roof support should sit in the notch cut out in the panels.

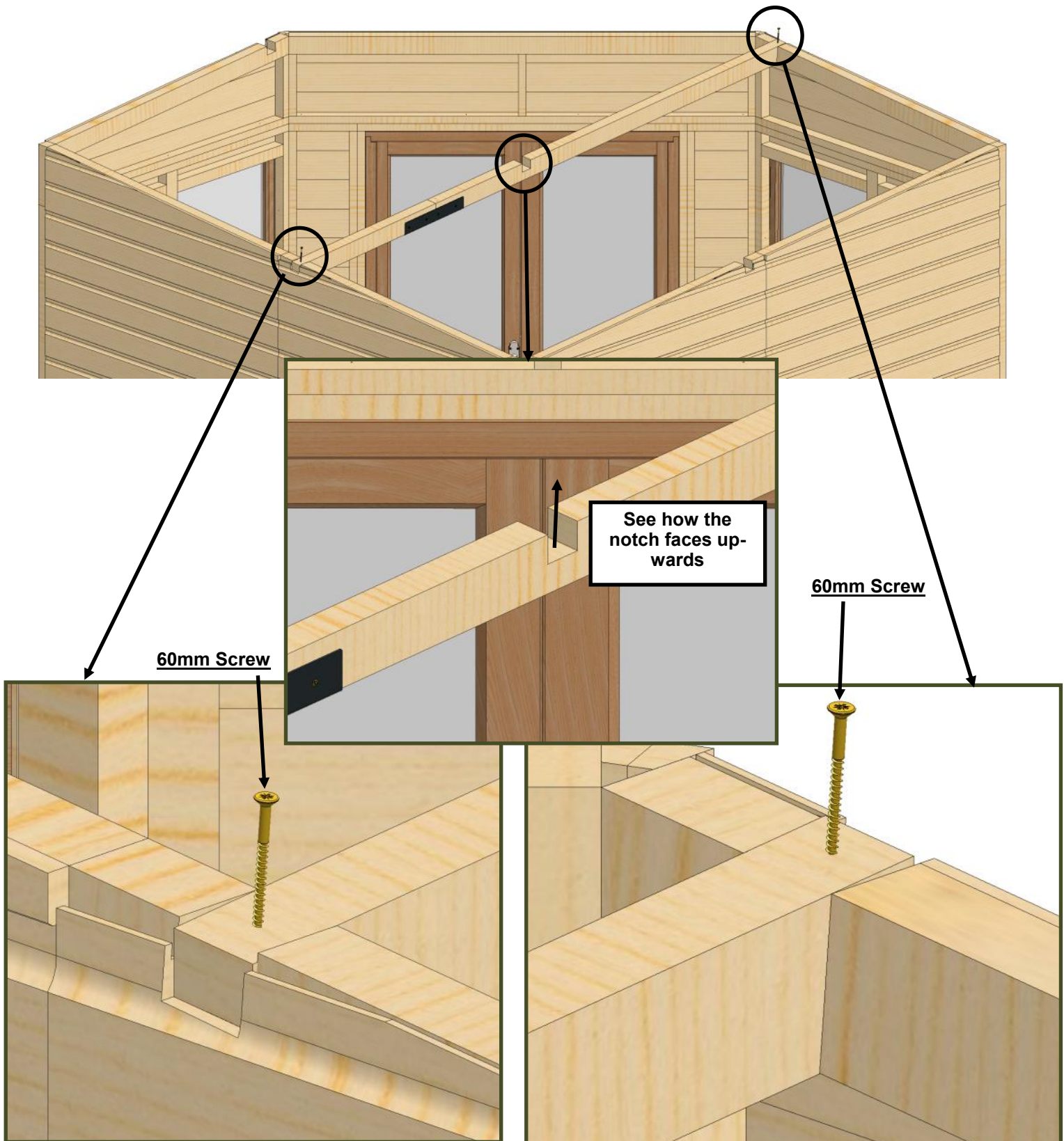

You can now install the other roof support that you previously assembled. This one will slot on top of the one you have previously installed and attach to the side panels exactly like before.

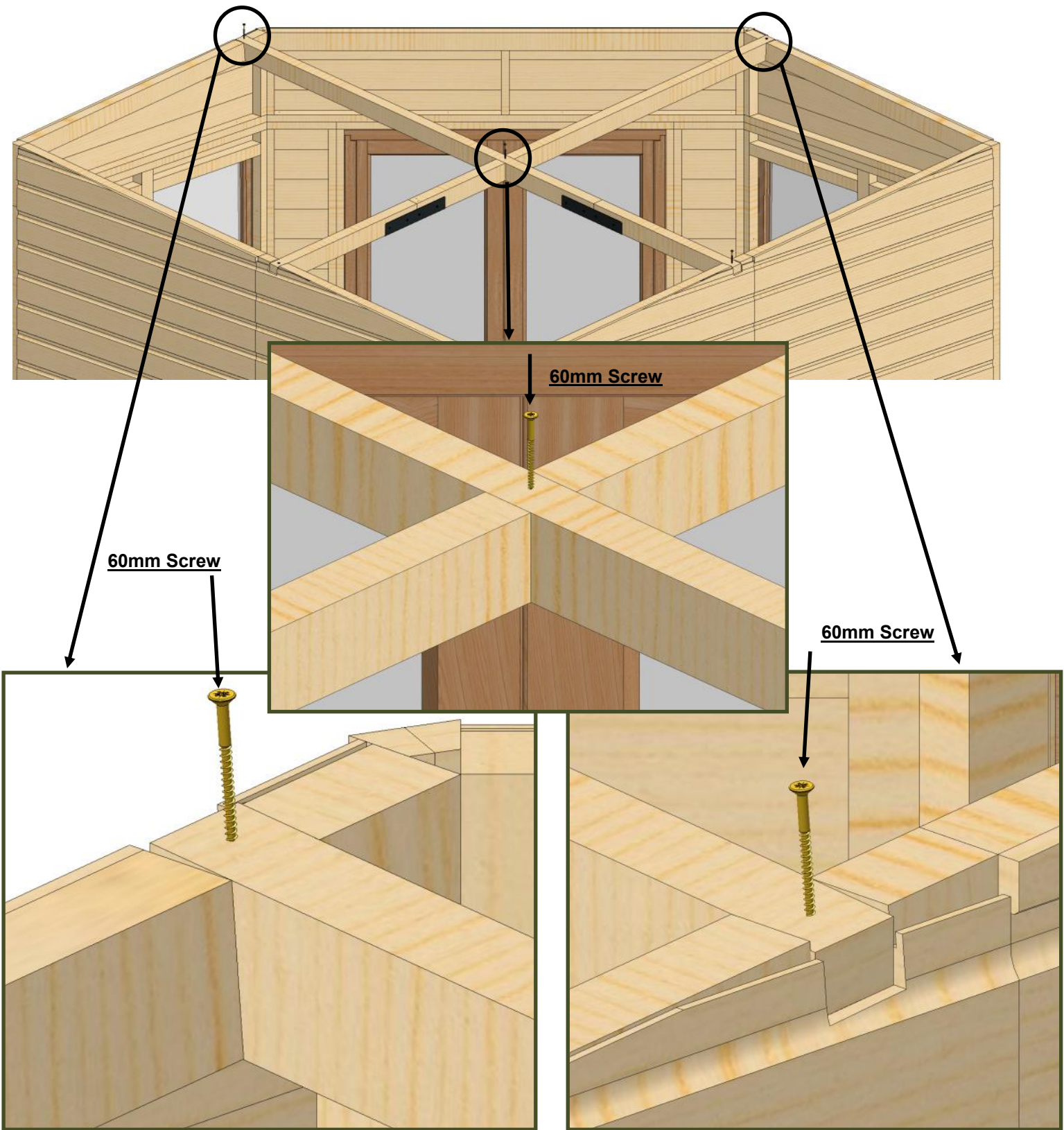

# Roof Assembly

You will receive the 4 roof panels as seen below.

**ASA1117**

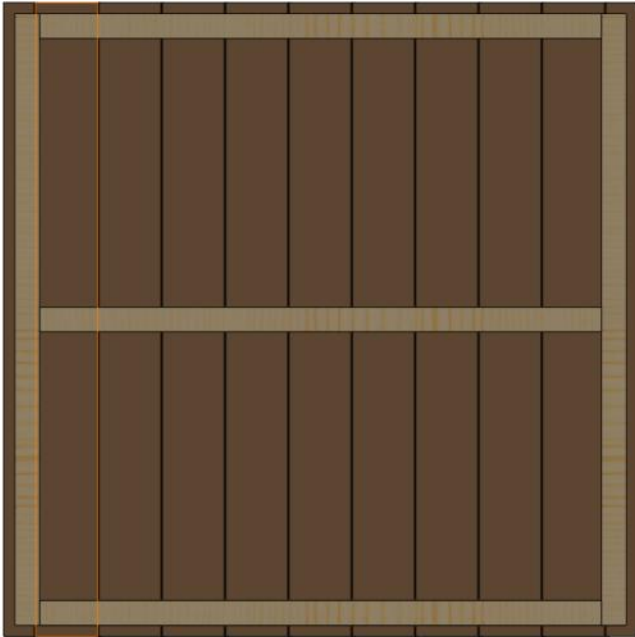

**ASA1116**



**ASA1115**

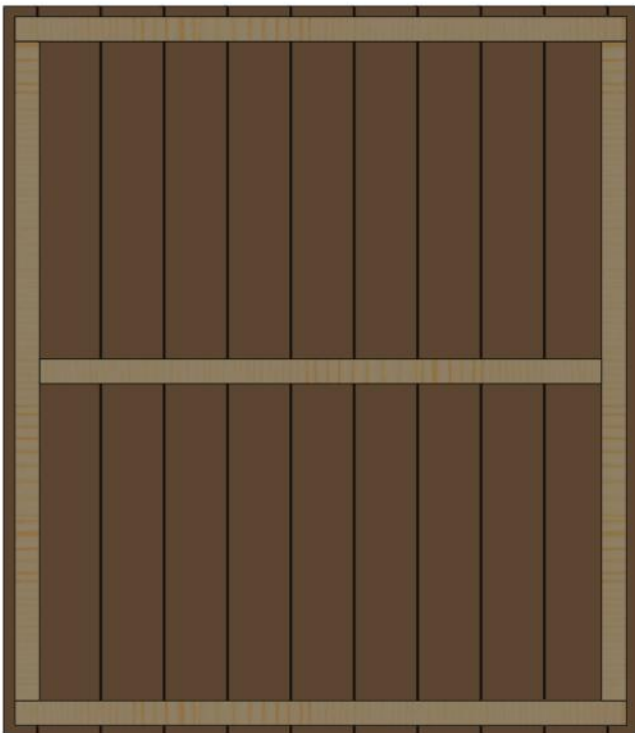

**ASA1118**

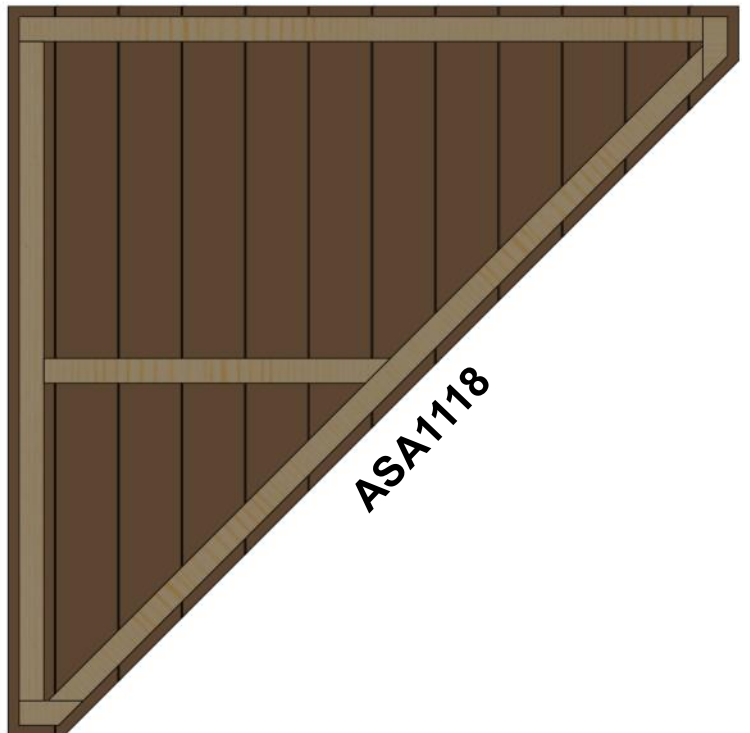

## Roof Assembly

The board on the roof panels overhangs the frame, this allows the board to rest on the actual building and then you can use **60mm screws** to secure each side of the roof panels to the building. See below.

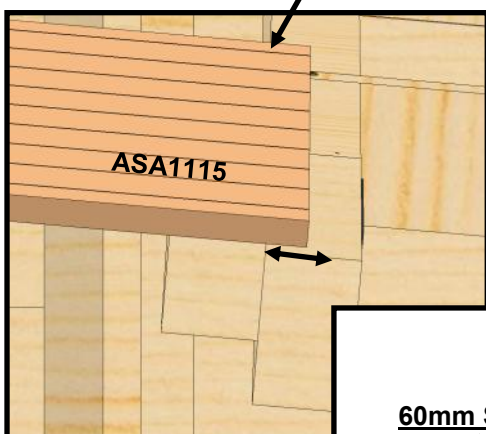
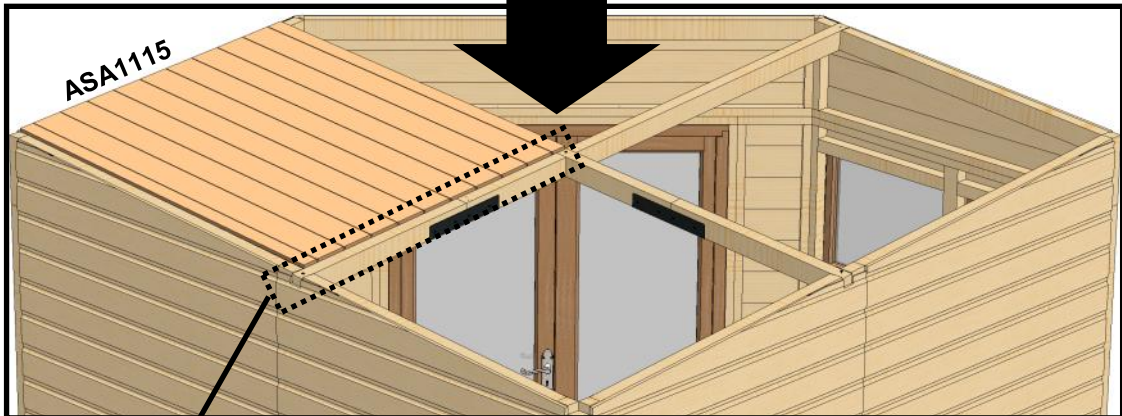
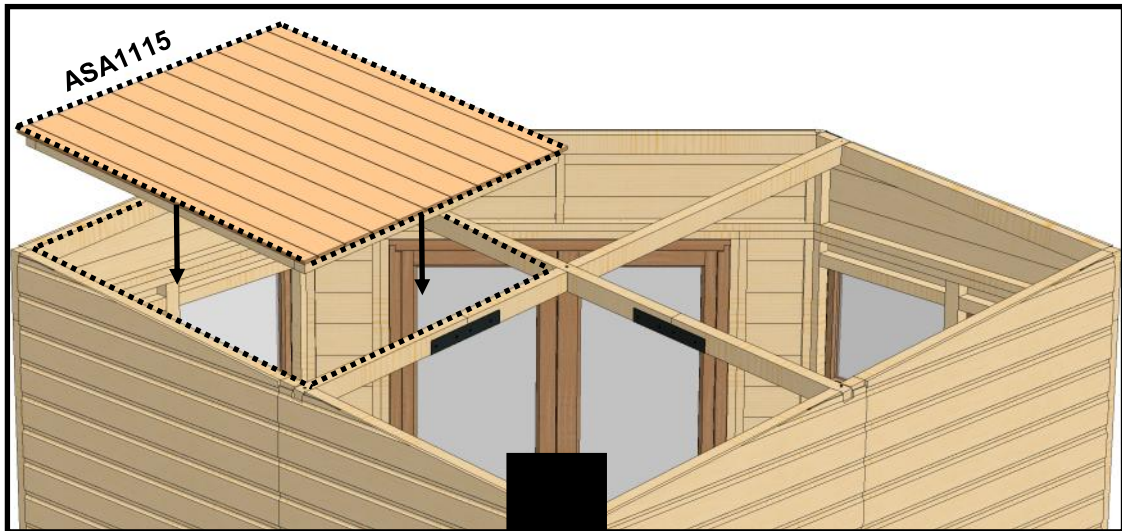

Inside View

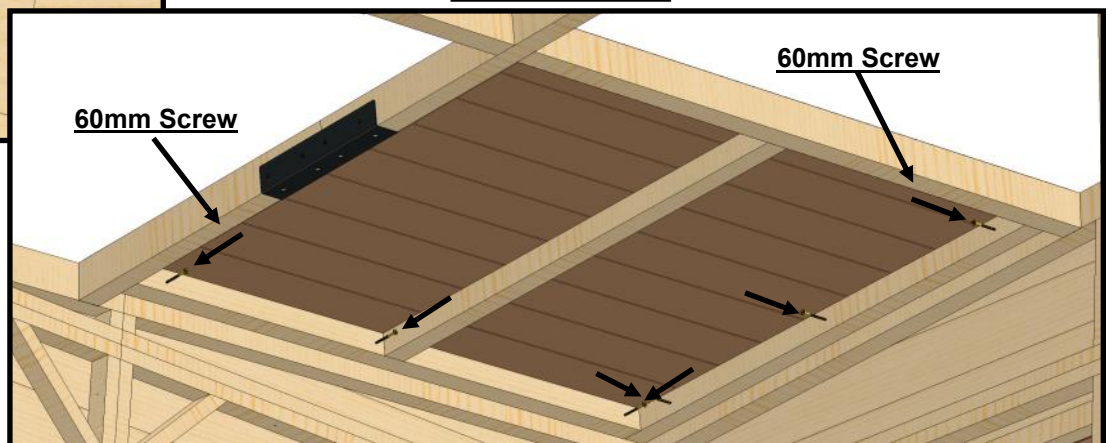

## Roof Assembly

Repeat all of these steps for the rest of the roof panels, set out like the below:

**TIP:** Make sure all of the boards go the same way so you get the correct orientation of the roof panels.

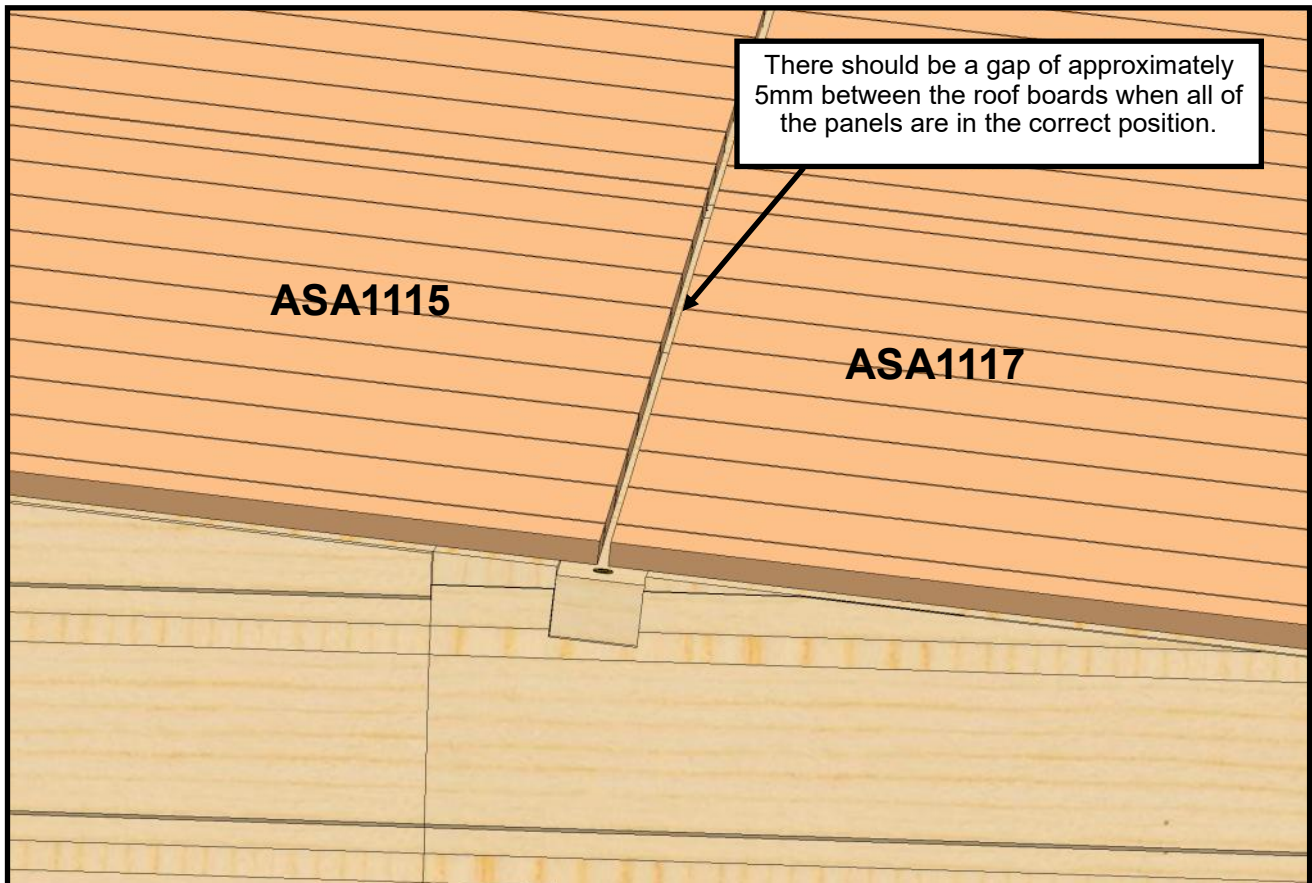
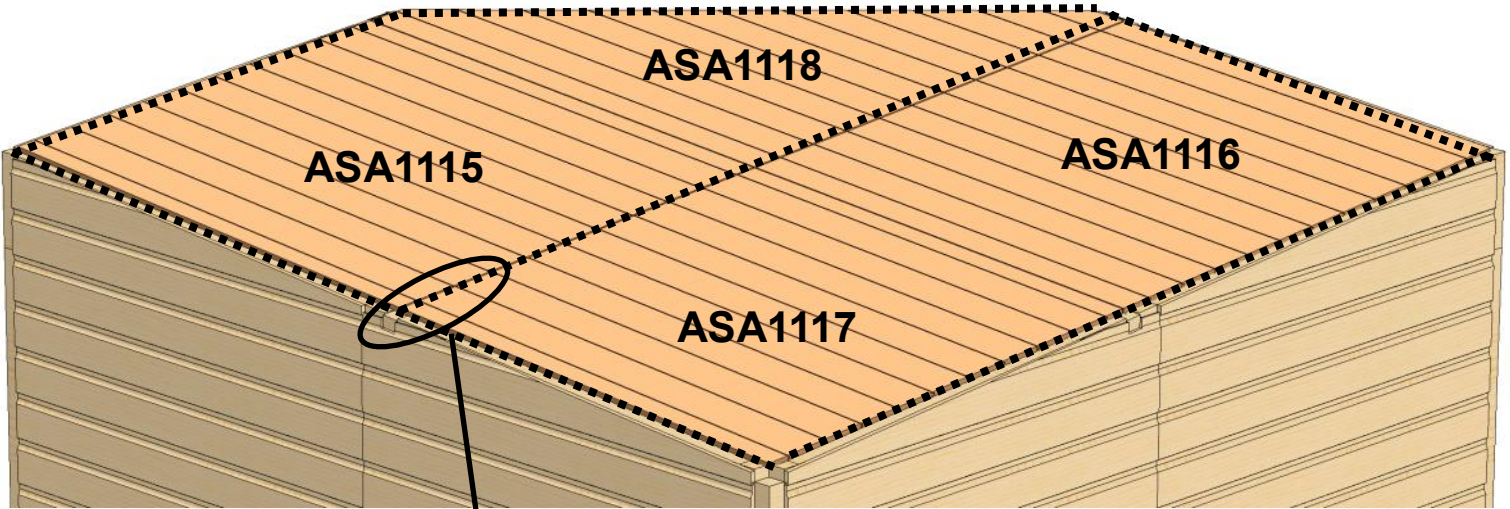

## Roof Assembly

You can now install your **AS357** batons. These are important for when you put the felt onto the roof.  
Attach these with **3 x 60mm screws** on each one.

See the image at the bottom of the page on where to position these batons before securing to the building.

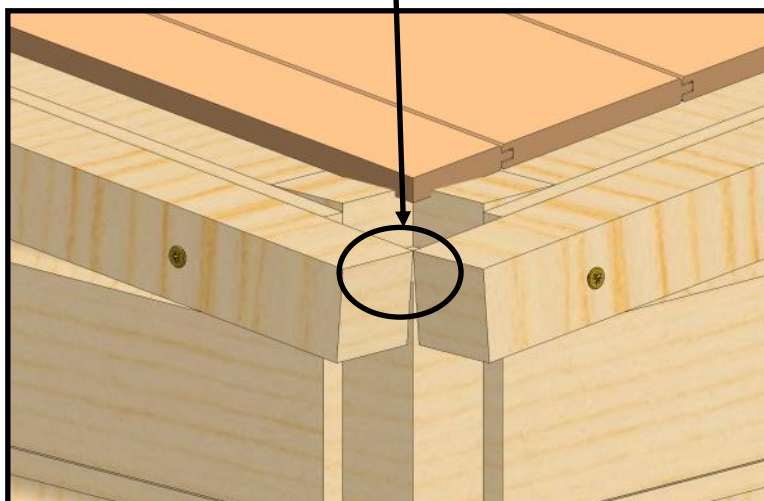
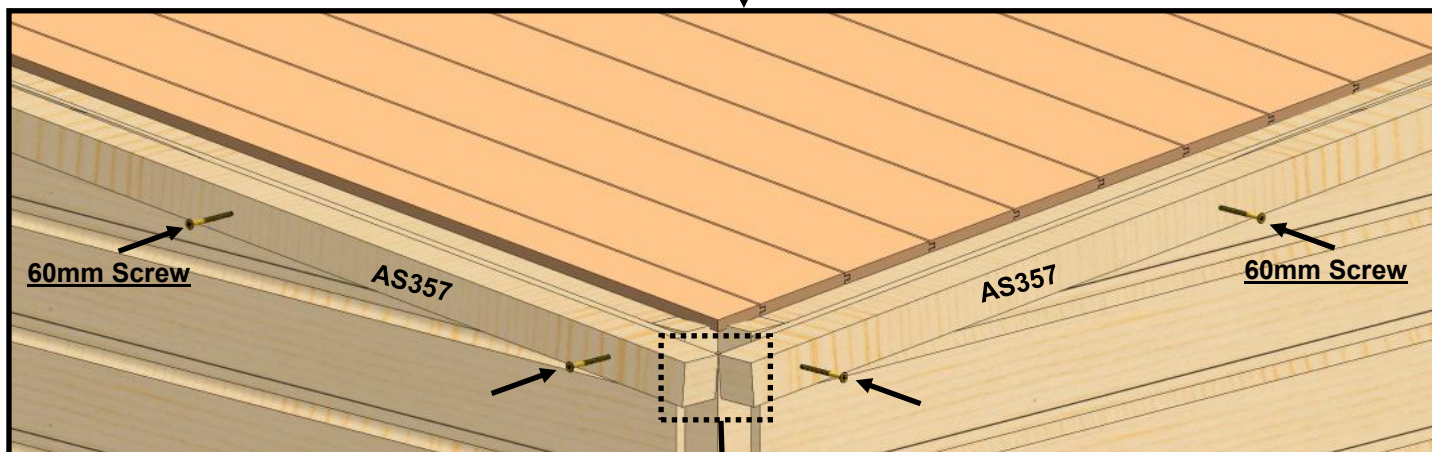
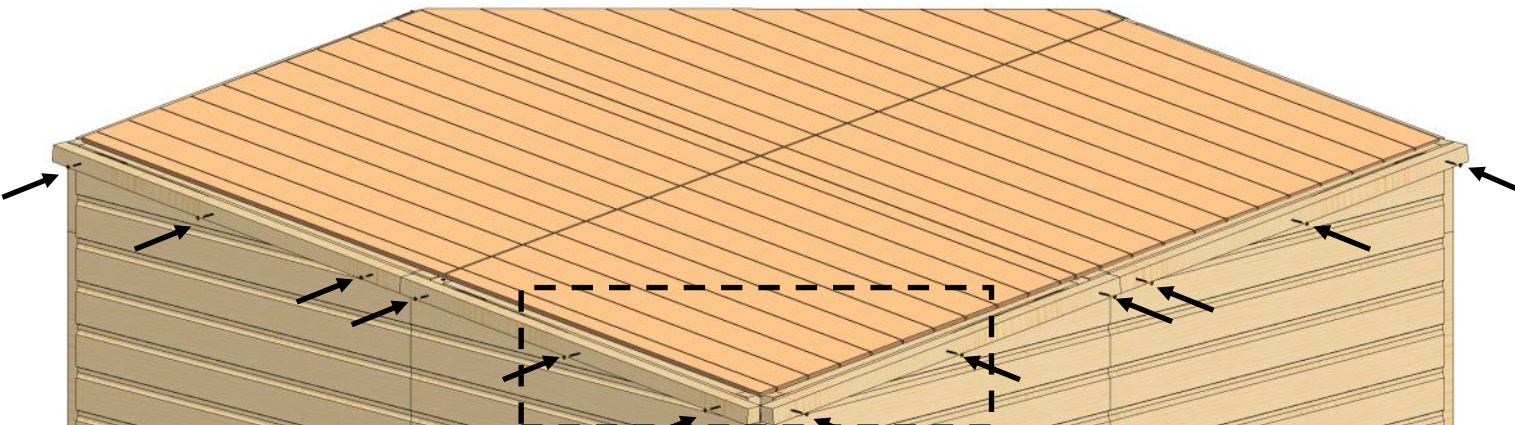

The two **AS357** should meet in the corner to get the correct position. See the image to the left

# Roof Assembly

You can now install your **AS358/359** batons. These are also important for when you put the felt onto the roof.

Attach these with **3 x 60mm screws** on each one.

See the image at the bottom of the page on where to position these batons before securing to the building.

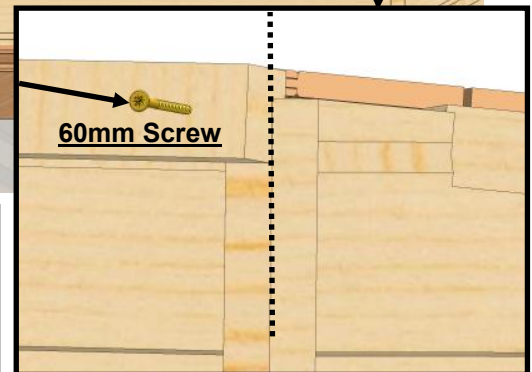
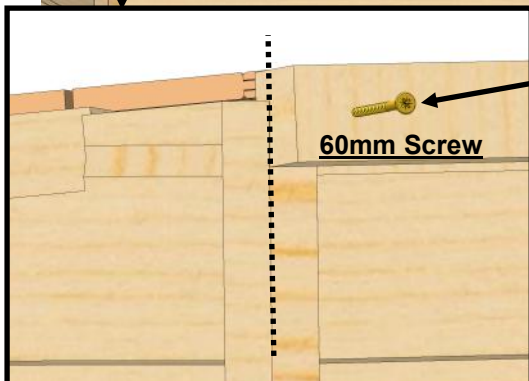

See the dotted line in the pictures either side. You need to line up each corner of the **AS359** with the edge of the wedge you installed onto the panel. This puts it into the correct position before you install the **2 x AS358**

RIGHT

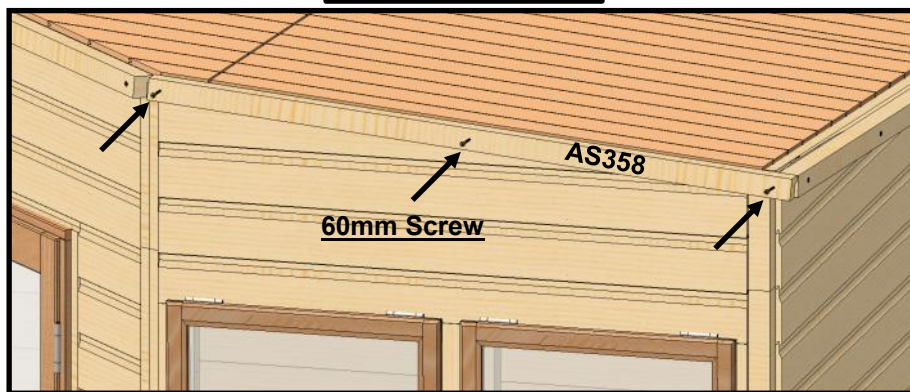

See how the **AS358** will butt up to the edge of the previously installed **AS359**. Do this to help get it in the correct position before you secure it with **3 x 60mm screws**

LEFT

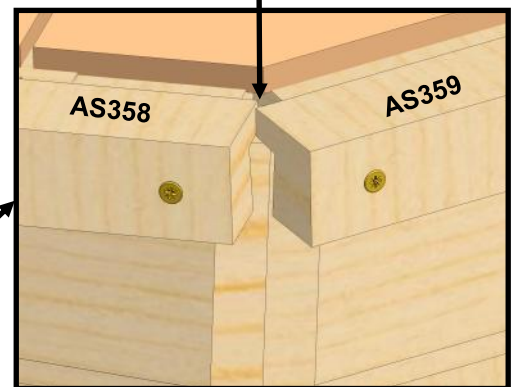

## Felt

Now it is time to cut install your felt. You will receive **1 x AS314 (1m x 10m Roll)** and **1 x AS310 (1m x 4.1m).**

First, you need take your roll of felt and lay it down somewhere felt such as a garage floor or a patio. Use a sharp knife to cut the felt to the below lengths.

You can use your **10m roll** to get your felt for pieces **A, B and D**

You can then use your **4.1m roll** to cut you felt for piece **C**

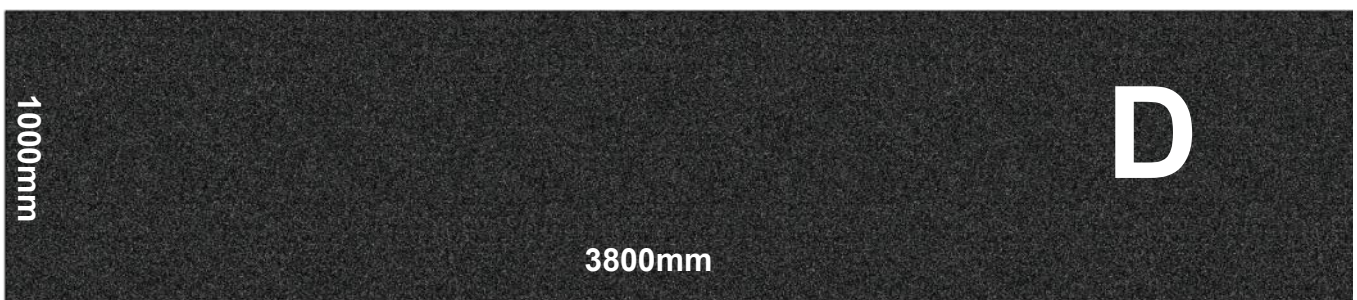
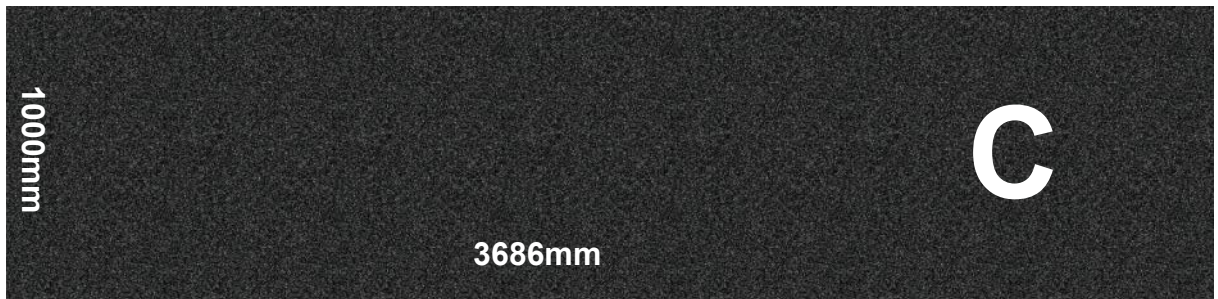
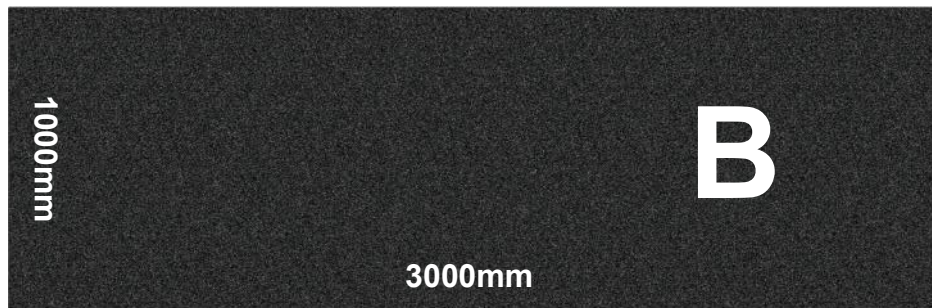
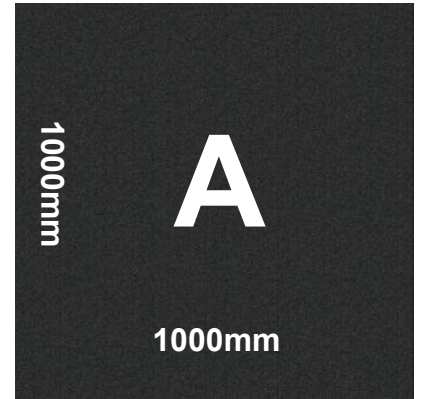

# Felt

Before you lift the pieces of felt up to the roof, roll the felt back up to make it easier for you to lift without damaging the felt. See below for the correct lay out and how to fit attach the felt to the building

Once you have cut your felt to the correct lengths, roll it back up and place it on top of the roof. Its easier to move around if you roll it back up. Position the roll of felt 'A' at the back of the roof as that is the bottom of the slope, this is so when the next pieces overlap, the water wont run inside of the felt. Once its rolled out, space it out evenly so that it overhangs 50mm evenly over each gable end and around 2mm at the eaves of the roof. Now its in the correct position, place a Felt clout at each top edge to stop it from sliding. Pull it down so its nice and flat and begin to tac at the eaves.

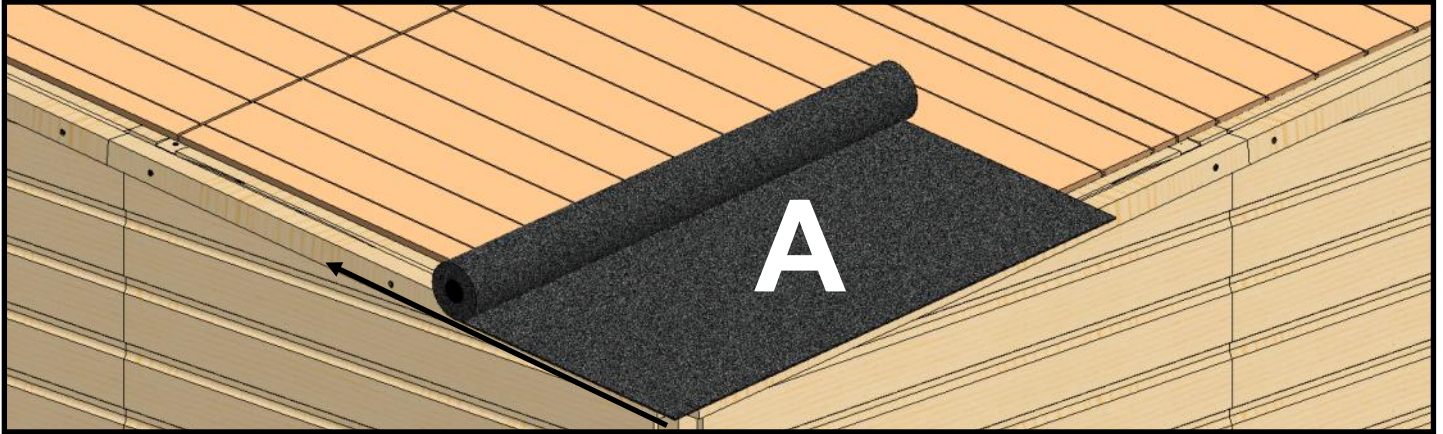

Felt clout paced at the top to stop it from sliding down.

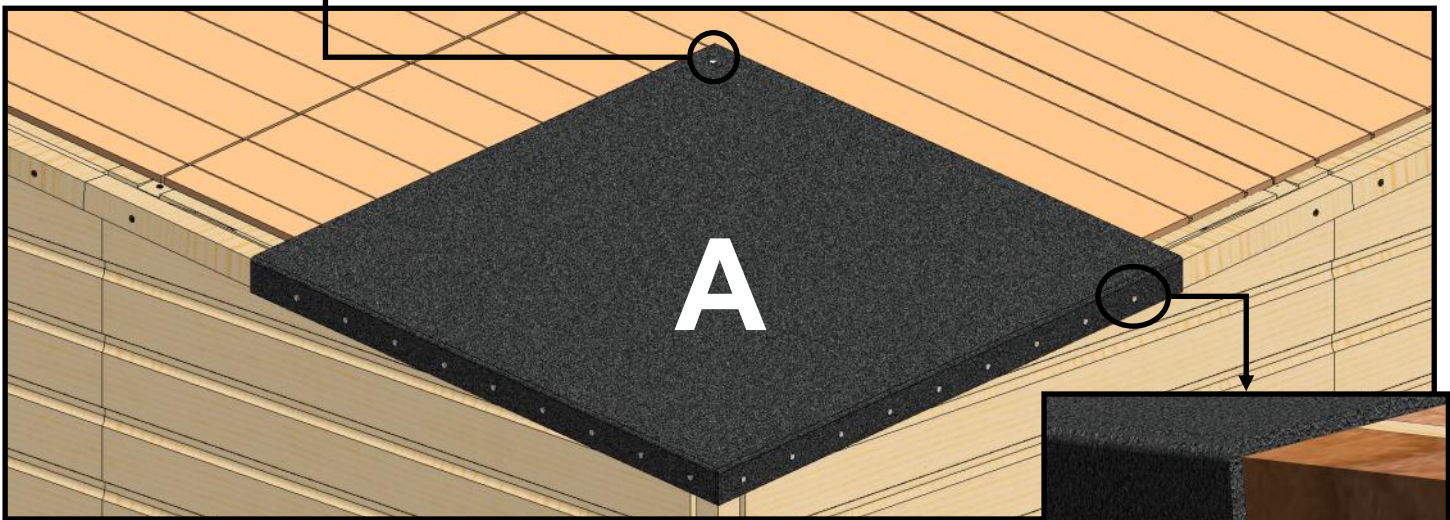

Place tacs approx. every 100mm spaced evenly or use your hammer to get a consistent spacing between each tac.

The felt should overhang slightly by about 2mm. It should not be tucked under or nailed 'up'. Also overhang the end by 50mm

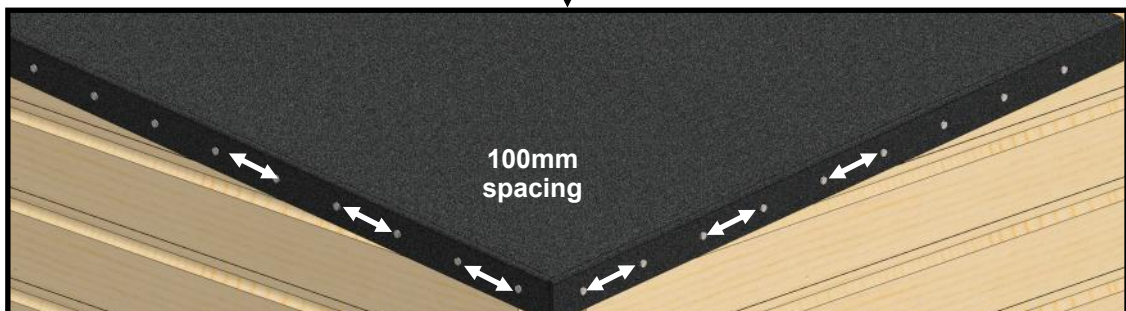
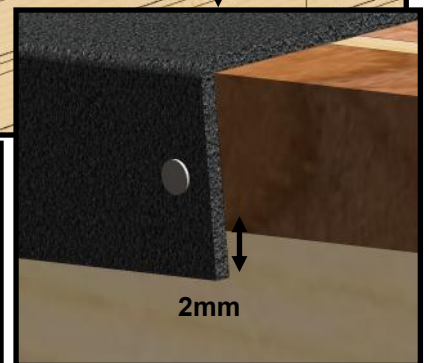

You can now place piece 'B'. Roll it out across felt 'A' and position it so that it overlaps over half of felt 'A' so that there are no gaps showing the roof so water wont run under neath the felt. Once in position and evenly spaced, place a tac at the top to stop it from moving, see below.

**IMPORTANT**  
You will need to cut off any of the excess overhang- ing felt to keep the 2mm over- hang. You can do this is a sharp knife. See dotted line.

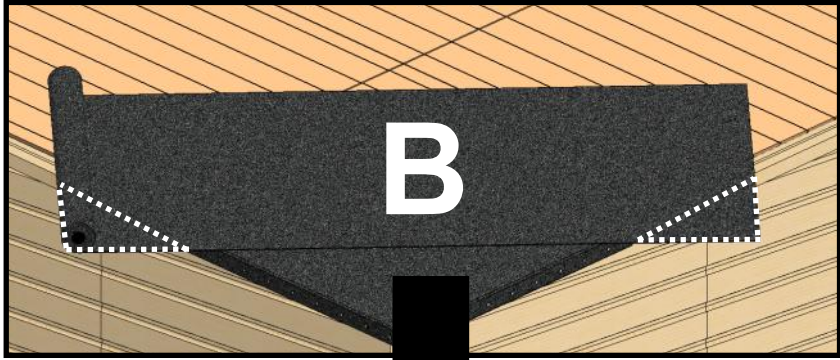

Felt clout paced at the top to stop it from sliding down.

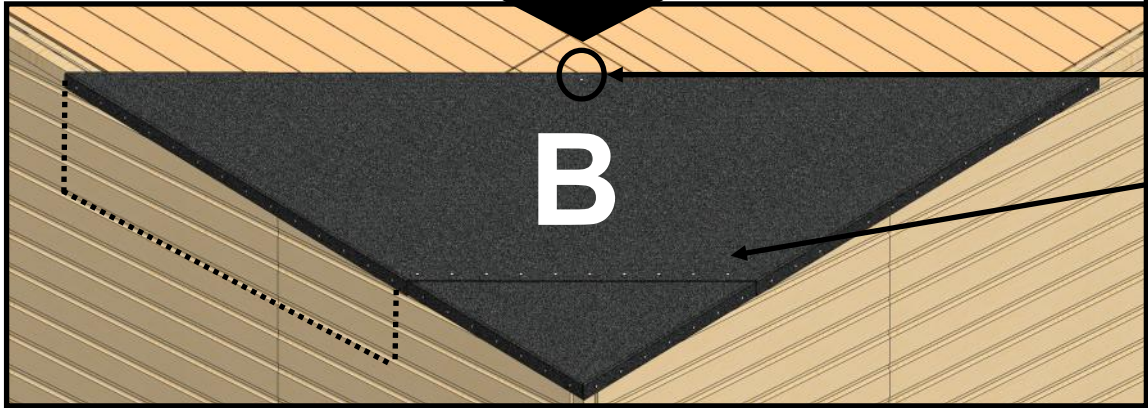

Place tacs every 100mm across the roof on the bottom part of the felt to se- cure it down. Please take caution when leaning on the roof.

Repeat the previous steps to of rolling the felt 'C' out on top of the previously placed felt 'B'. You want to achieve an overlap of around 150mm to stop any water ingress. Making sure the felt still overhands the roof by 2mm to allow water to drop off and not track back up underneath the felt.

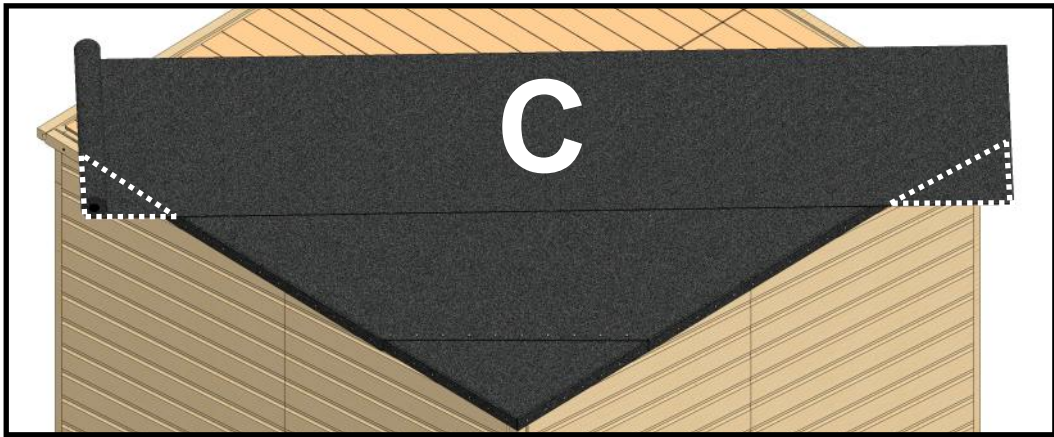

**IMPORTANT**  
You will need to cut off any of the excess overhang- ing felt to keep the 2mm over- hang. You can do this with a sharp knife. See dotted line

Felt clout paced at the top to stop it from sliding down.

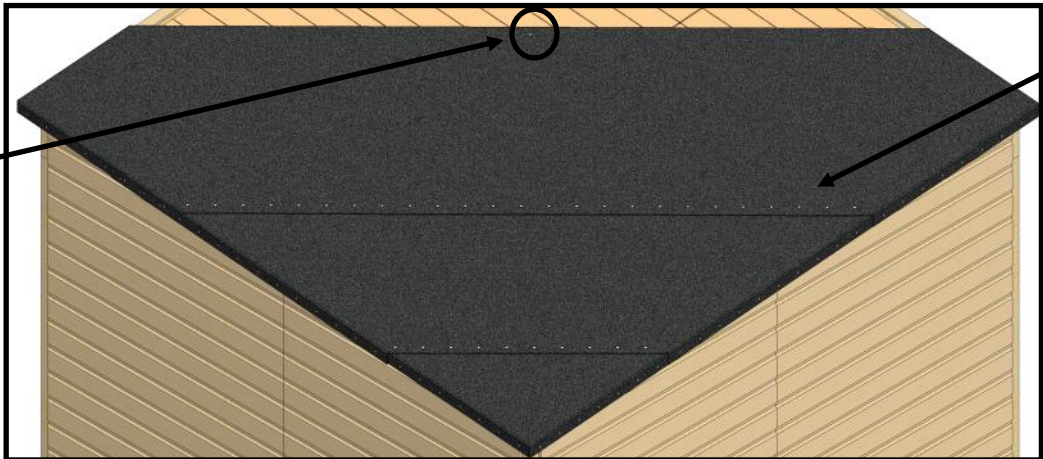

Place tacs every 100mm across the roof on the bottom part of the felt to se- cure it down. **Please take caution when leaning on the roof.**

## Felt

You can now place piece 'D'. Roll it out across felt 'C' and position it so that it overlaps over half of felt 'C' so that there are no gaps showing the roof so water wont run under neath the felt. See below for where to secure the felt down

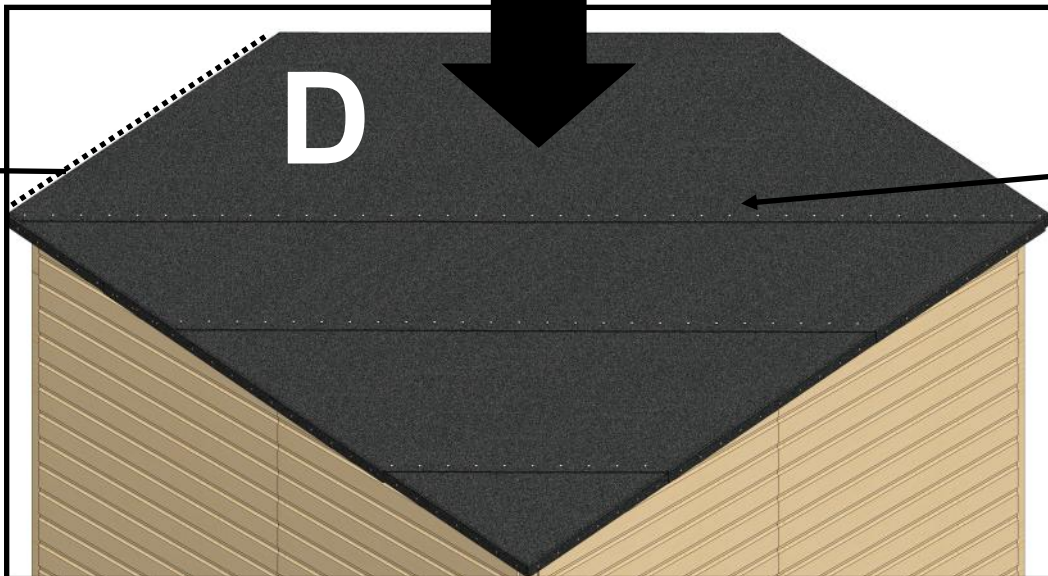
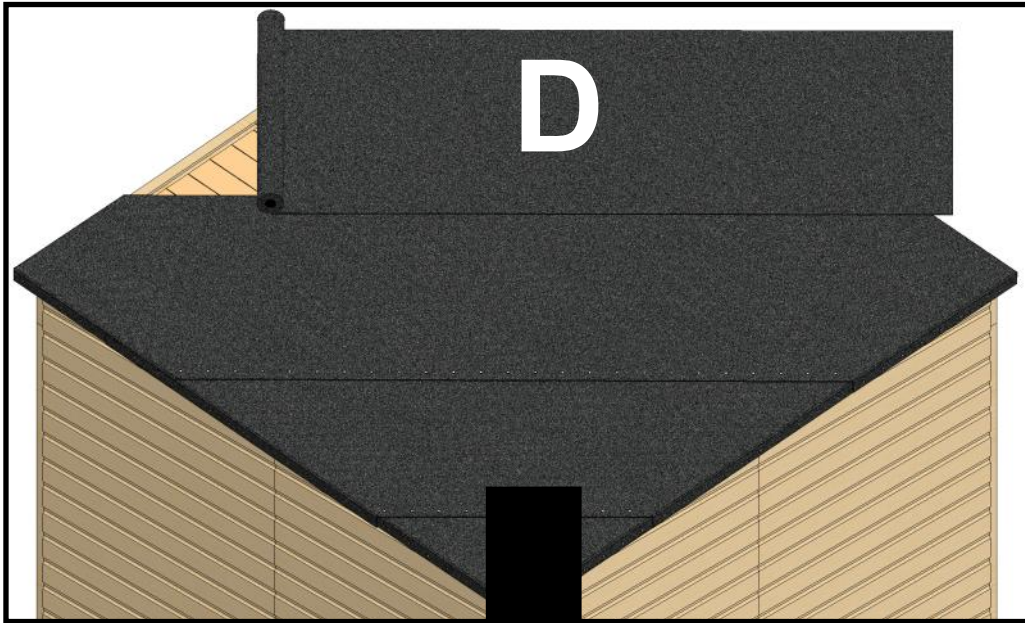

Place tacs every 100mm across the roof on the bottom part of the felt to secure it down. **Please take caution when leaning on the roof.**

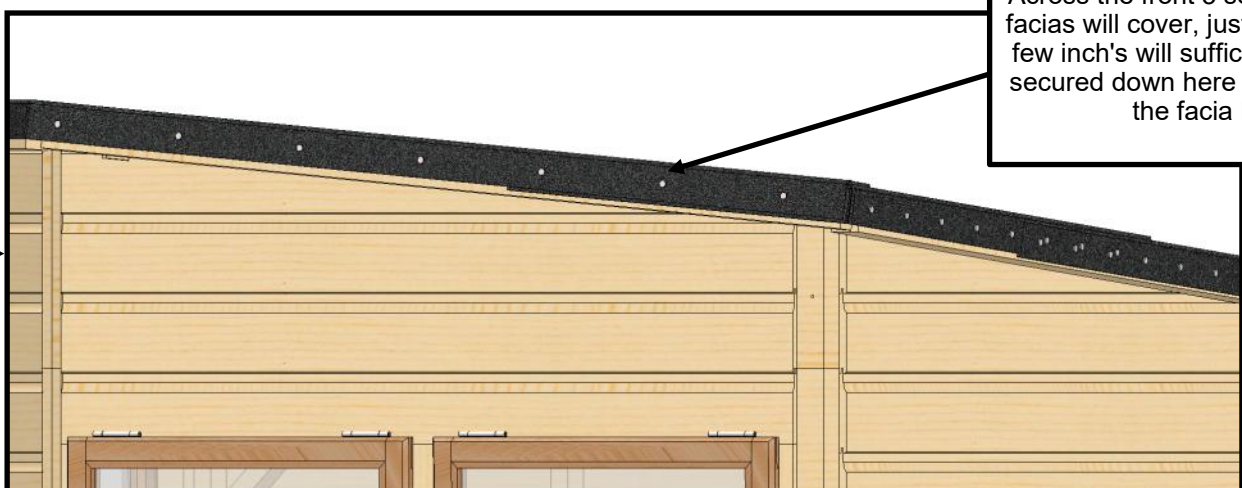

Across the front 3 sections where the fascias will cover, just a few tacs every few inch's will suffice. The felt will be secured down here when covered the fascia boards

## Facias and Capping

You can now install your **AS361** and **AS360** fascia boards with **4 x 35mm screws** on each one. See below for the correct lay out. You should make the top of the fascia board flush with the felt on the roof.

Position the screws towards the top half of the fascia board so that you screw into the **AS358** and **AS359** you installed on page 20.

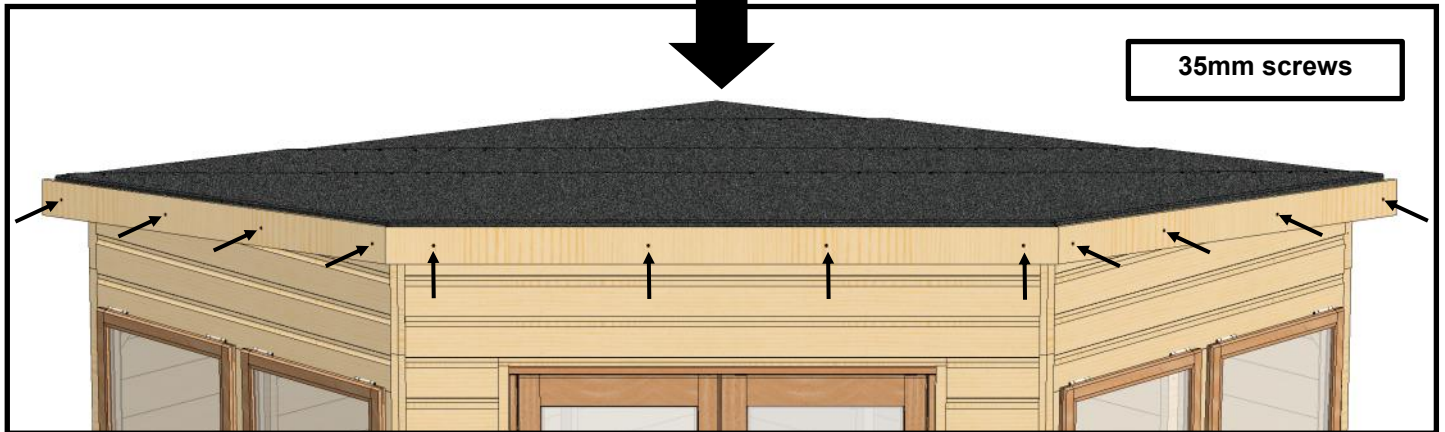
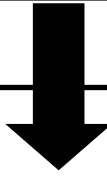
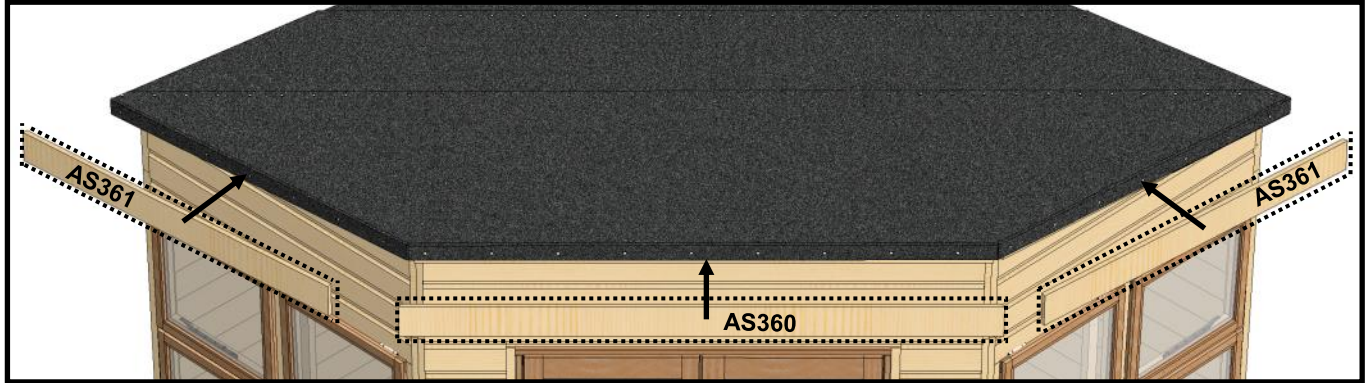

the  
ery  
be  
by

# Trims

You can go around the building attaching the **12x56** pieces using **40mm galvanised nails**

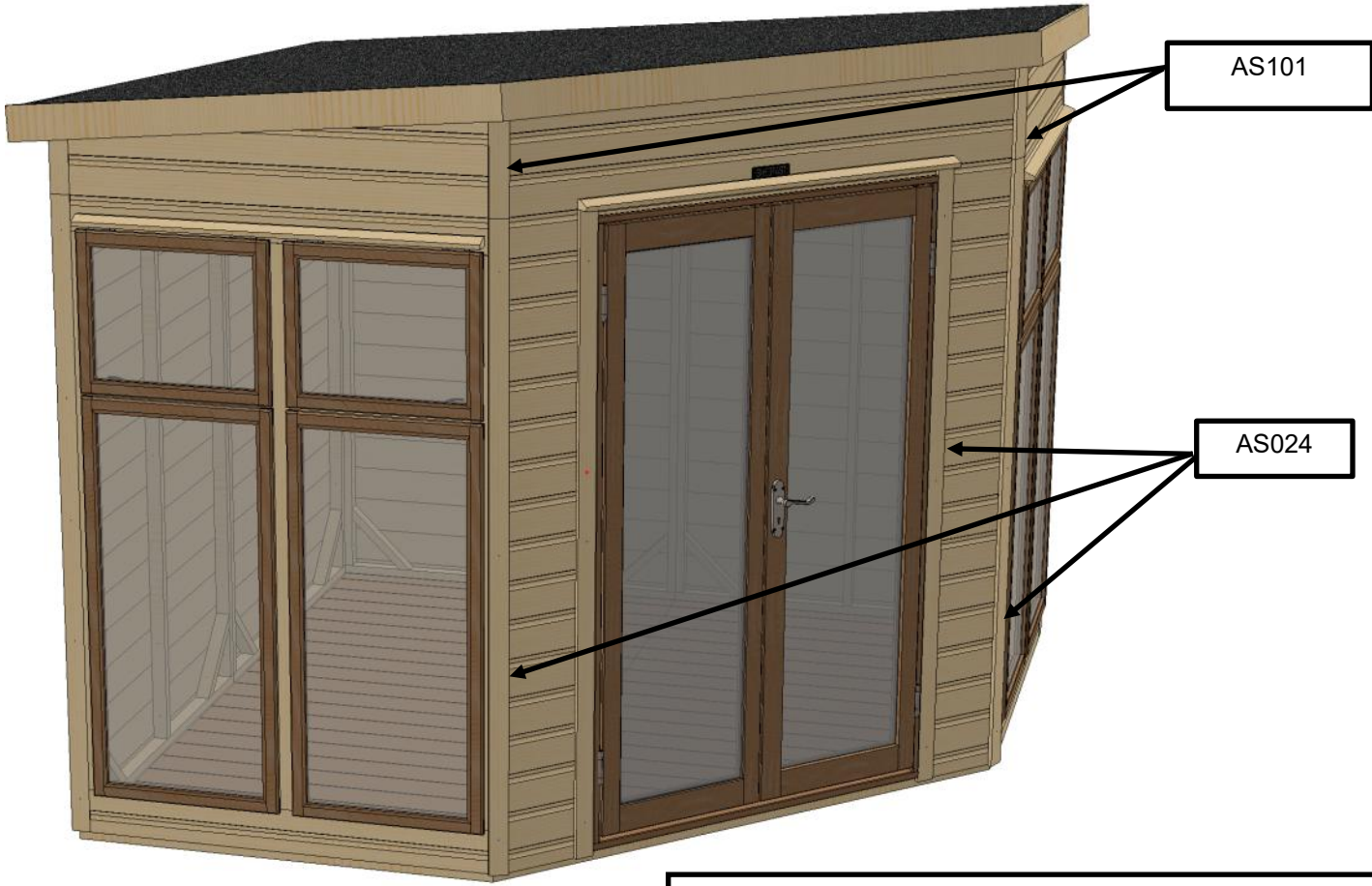

40mm galvanised nails

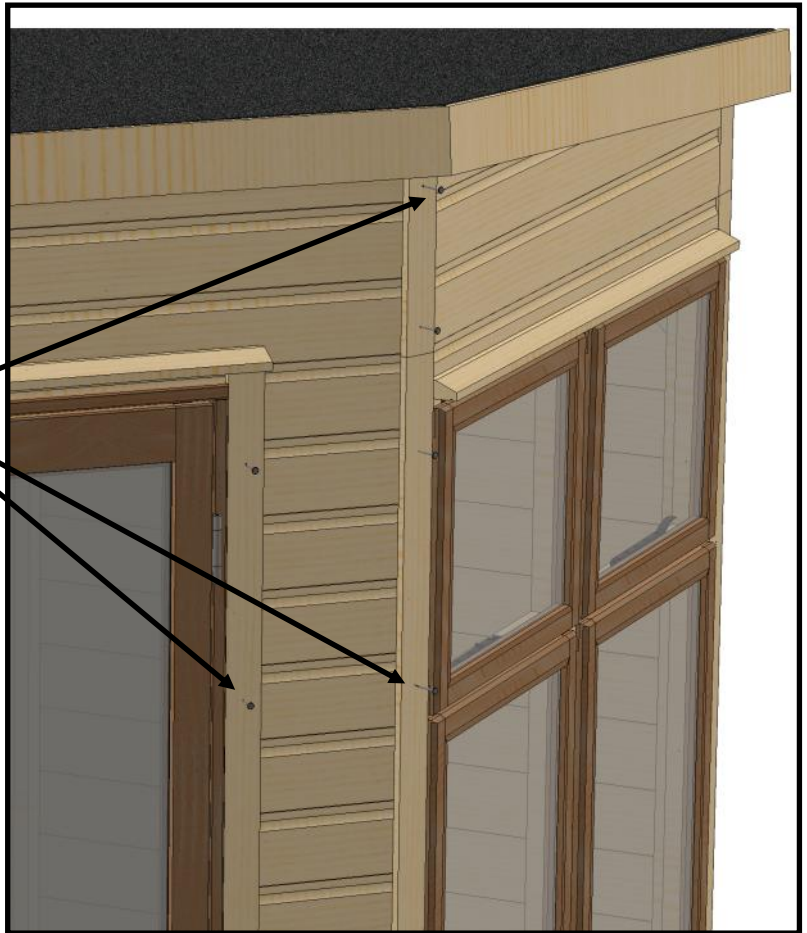





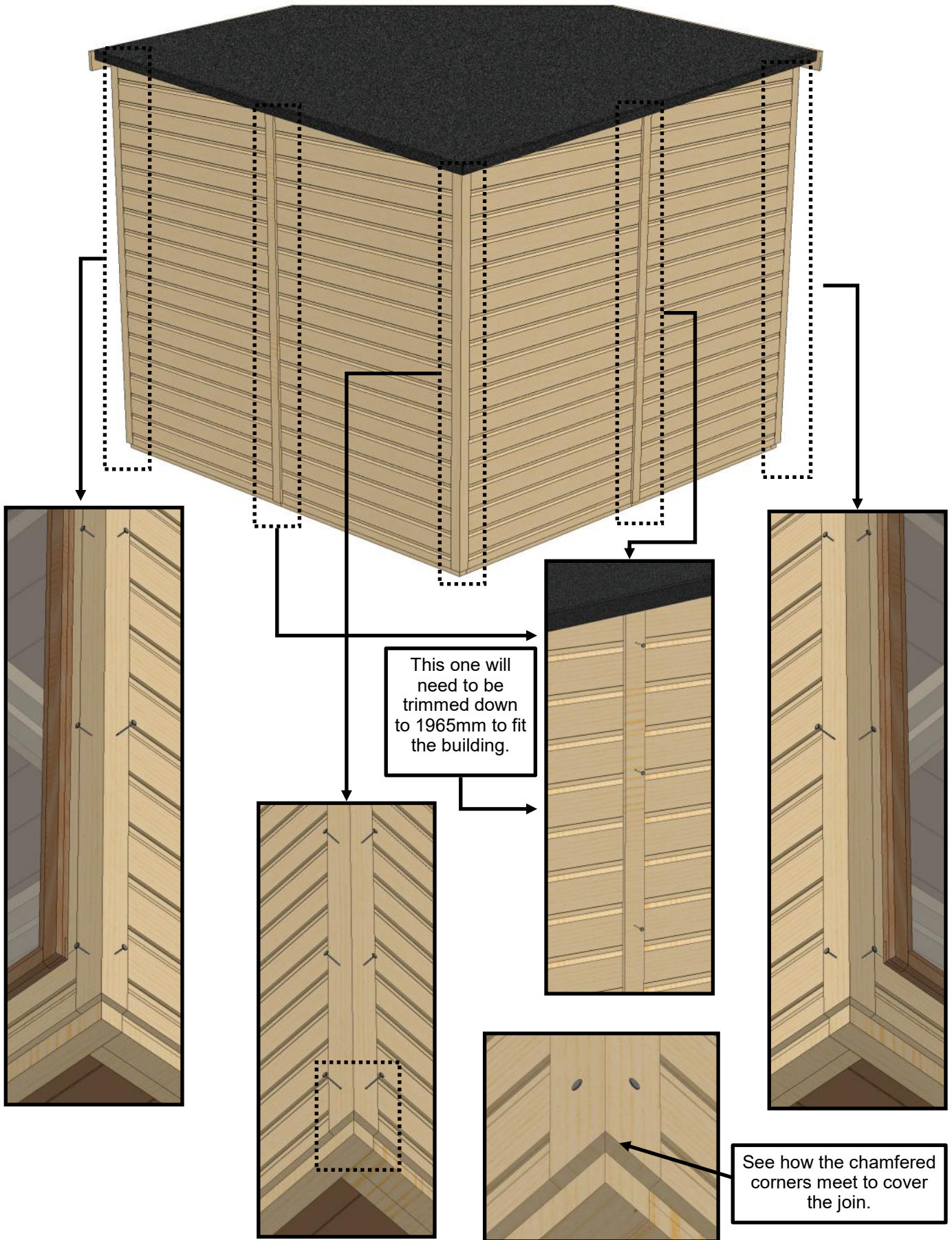



# Trims

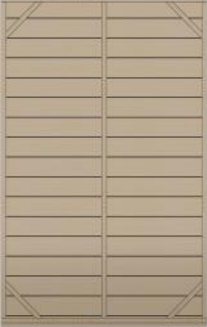

The 12x56 trims with a 45 degree chamfer are for the outer edges and the rear. Like before, use a hammer and the **40mm galvanised nails**. You may need to trim some of the 12x56 trims down to length. See below for how they fit:



# Standard Product Tables

	<b>ASA1107</b> Side of door panel 249x1856	<b>ASA1108</b> Above Door Panel 339x1200	<b>ASA1086 Opening</b> Window Panel 1200x1856	<b>ASA1006 4ft</b> Panel 1200x1856	<b>ASA1088 Double</b> Door Panel 1200x1856
					
<b>8x8</b>	2	1	2	4	1

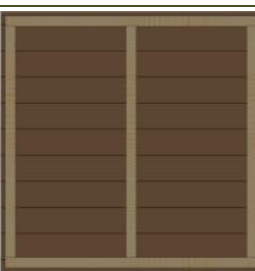
	<b>ASA1109</b> RH Angle Panel 339x1200	<b>ASA1110</b> LH Angle Panel 339x1200	<b>ASA1111</b> RH Angle Panel 234x1200	<b>ASA1112</b> LH Angle Panel 234x1200	<b>ASA1113</b> RH Angle Panel 129x1200	<b>ASA1114</b> LH Angle Panel 129x1200
						
<b>8x8</b>	1	1	1	1	1	1

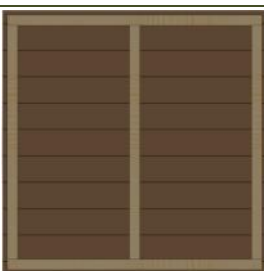
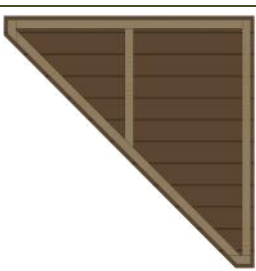
	<b>ASA1115</b> Roof Panel 1263x1090	<b>ASA1116</b> Roof Panel 1090x1263	<b>ASA1117</b> Roof Panel 1090x1090	<b>ASA1118</b> Corner Roof Panel 70x1263x1090
				
<b>8x8</b>	1	1	1	1

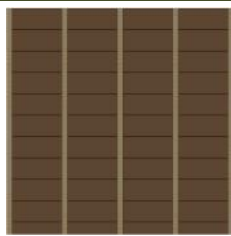
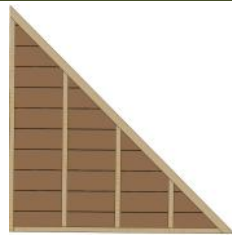
	<b>ASA1023 4x4 Floor</b> 1195x1195	<b>ASA1119</b> Corner Floor 1239x1239
		
<b>8x8</b>	3	1

	<b>AS357</b> 44x44 1252mm	<b>AS364</b> 44x44 1856mm	<b>AS352</b> 44x69 767mm	<b>AS371</b> 44x56 1752mm	<b>AS353</b> 44x69 1800mm	<b>AS354</b> 44x69 1800mm	<b>AS101</b> 12x56 295mm	<b>AS190</b> Roof Bar Brace	<b>AS441</b> Weather Strip 1256mm
<b>8x8</b>	4	3	2	1	1	1	2	2	1

	<b>AS362</b> 44x44 1097mm	<b>AS365</b> 44x44 234mm	<b>AS358</b> 44x44 1309mm	<b>AS359</b> 44x44 1756mm	<b>AS361 Facia</b> 19x100 1400mm	<b>AS360 Facia</b> 19x100 1791mm
<b>8x8</b>	4	2	2	1	2	1

	<b>AS041X2</b> 56x44 1195mm	<b>AS372</b> 44x56 1239mm	<b>AS440</b> 12x56 224mm	<b>AS439</b> 12x56 1876mm	<b>AS189</b> Weather Strip 1162mm	<b>AS024</b> 12x56 1876mm	<b>AS172</b> 12x56 2120mm	<b>AS306</b> Shedfast Name Badge
<b>8x8</b>	3	3	4	4	2	2	2	1

	<b>Felt codes</b>	
	<b>AS310</b> 1m Wide x 4.1 Long	<b>AS314</b> 1m wide x 10m Long
<b>8x8</b>	1	1

# 8ft CORNER



## Unpacking Pallet

The first thing you need to do is carefully unpack the pallet. Each panel is screwed to the diagonals at the top and bottom. Remove each panel, one at a time, by unscrewing the screws at the top and bottom. Take the panel off the pallet and place it somewhere safe.

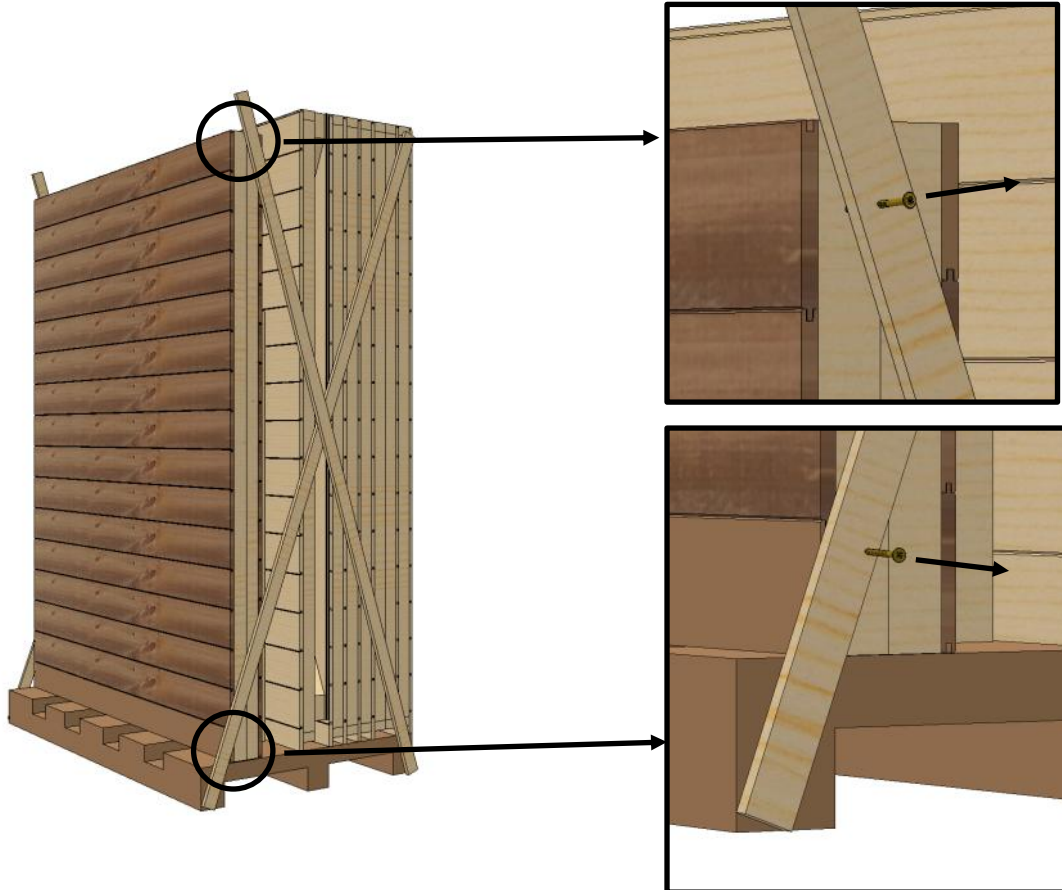

# SHEEDFAST

[www.greenhousepeople.co.uk](http://www.greenhousepeople.co.uk)

Call us on 01782 385400

The Greenhouse People Ltd, Unit 19 Blythe Park, Cresswell, Stoke-on-Trent, Staffordshire, ST11 9RD